

American University in Cairo

AUC Knowledge Fountain

Theses and Dissertations

Student Research

2-1-2018

Expression analysis of liver-specific circulating micrnas in hcv-induced hepatocellular carcinoma in Egyptian patients

Lobna Mohamed Mourad

Follow this and additional works at: <https://fount.aucegypt.edu/etds>

Recommended Citation

APA Citation

Mourad, L. (2018). *Expression analysis of liver-specific circulating micrnas in hcv-induced hepatocellular carcinoma in Egyptian patients* [Doctoral Dissertation, the American University in Cairo]. AUC Knowledge Fountain.

<https://fount.aucegypt.edu/etds/2>

MLA Citation

Mourad, Lobna Mohamed. *Expression analysis of liver-specific circulating micrnas in hcv-induced hepatocellular carcinoma in Egyptian patients*. 2018. American University in Cairo, Doctoral Dissertation. *AUC Knowledge Fountain*.

<https://fount.aucegypt.edu/etds/2>

This Doctoral Dissertation is brought to you for free and open access by the Student Research at AUC Knowledge Fountain. It has been accepted for inclusion in Theses and Dissertations by an authorized administrator of AUC Knowledge Fountain. For more information, please contact thesisadmin@aucegypt.edu.

The American University in Cairo

School of Science and Engineering



Expression Analysis of Liver-Specific Circulating MicroRNAs in HCV-
Induced Hepatocellular Carcinoma in Egyptian Patients

A Thesis Submitted to

The Biotechnology Graduate Program

In Partial Fulfillment of the Requirements for
The Degree of Doctor of Philosophy

BY

Lobna Mohamed Mourad

BSc in Biology, American University in Cairo, 2007
MSc in Biotechnology, American University in Cairo, 2010

Supervised By

Suher Zada, Ph.D.

Professor of Immunology

Biology Department, The American University in Cairo

Eman El Ahwany, Ph.D.

Professor of Immunology

Immunology and Evaluation Therapy Department, Theodor Bilharz Research
Institute

DEDICATION

I would like to dedicate this project to my dear parents whom without their support I would never be where I am today. I consider myself the luckiest person alive just because I have the best mom and dad anyone could ask for. Thank you for teaching me to dream big and to work endlessly for what I want. Thank you for investing the time and money so I can build the future I have always dreamed of, and for always believing in me. This is also dedicated it to my dear husband who supported me every step of the way, thank you my dear for believing in me and encouraging me to pursue my dreams. I never thought I would be that lucky to have a best friend and a husband like you. To my beloved son, Omar, thank you for being in my life and lighting it with love and laughter, for you dear I try to be the best version of myself every day. Million thanks to my dearest brother who always gave me words of encouragement when I needed them the most and for always expressing how proud you are of me. Finally, a very special dedication to my beloved late grandfather who always believed in my potential, I wish you were here to share this with but, I know you are looking down on me and I hope I have made you proud.

ACKNOWLEDGEMENTS

This project is a collaboration between Theodor Bilharz Research Institute (TBRI) and the American University in Cairo (AUC) Biotechnology graduate program. I would like to thank my great supervisor Dr. Suher Zada for giving me this great chance, thank you for your endless guidance and support, it has been an absolute honor being your student and learning from. Also, I would like to thank my co-supervisor at TBRI, Dr. Eman El-Ahwany, for her support and guidance in the laboratory work, data analyses, and for providing me with the patient samples. Thank you Dr. Eman for your constant help and for being a great mentor. I would like to acknowledge and sincerely thank Dr. Mona Zoheiry and Dr. Hoda Abu-Taleb for helping me with the data and statistical analyses. Special thanks to Mr. Amged Ouf for being there from the very beginning and providing valuable and endless guidance throughout the practical work. Additionally, I would like to thank TBRI for providing me with the patient samples and AUC for funding this project. Finally, I would like to thank everyone who contributed and helped with this project at AUC and TBRI.

TABLE OF CONTENTS

| | | |
|------|--|----|
| I. | ABSTRACT..... | 11 |
| II. | INTRODUCTION | 13 |
| III. | LITERATURE REVIEW | 15 |
| A. | Hepatitis C Virus..... | 15 |
| B. | Fibrosis and Cirrhosis..... | 18 |
| C. | Hepatocellular Carcinoma (HCC)..... | 19 |
| D. | MicroRNAs:..... | 20 |
| E. | Synthesis of MiRNAs:..... | 21 |
| i. | Key enzymes in the processing stage of pri-miRNA to pre-miRNA:..... | 23 |
| ii. | Key enzymes involved in the nuclear exportation of pre-miRNA:..... | 23 |
| iii. | Key enzymes involved in regulating the processing from pre-miRNA to mature miRNA:..... | 24 |
| F. | Epidemiology:..... | 24 |
| G. | HCC Molecular Classification:..... | 25 |
| H. | HCC Diagnosis:..... | 28 |
| i. | Screening and Surveillance Guidelines:..... | 29 |
| ii. | Biomarkers for HCC Screening:..... | 30 |
| iii. | Imaging Techniques for HCC Screening:..... | 33 |
| I. | MicroRNAs and HCC:..... | 34 |
| i. | MiR-34a:..... | 34 |
| ii. | MiR-221:..... | 39 |
| iii. | MiR-199a:..... | 42 |
| iv. | MiR-16:..... | 43 |

| | | |
|-------|--|----|
| v. | MiR-122a:..... | 45 |
| vi. | MiR-125a:..... | 48 |
| vii. | MiR 139:..... | 50 |
| viii. | MiR-145: | 51 |
| IV. | AIM OF THE STUDY..... | 54 |
| V. | MATERIALS AND METHODS..... | 55 |
| A. | Sample Collection | 55 |
| B. | Histopathologic Study | 56 |
| C. | Urine Analysis..... | 56 |
| D. | Stool Analysis | 57 |
| E. | Collection of Sera | 57 |
| F. | Liver Function Tests | 57 |
| G. | Detection of Circulating Anti-Schistosoma Antibodies..... | 57 |
| H. | Detection of Hepatitis B Surface Antigen (HBsAg) | 58 |
| I. | Detection of Anti-HCV (genotype 4) Antibodies..... | 58 |
| J. | Detection of HCV (genotype 4)-RNA | 59 |
| K. | RNA Extraction..... | 59 |
| L. | MicroRNA Selection Criteria | 60 |
| M. | Evaluating Serum MicroRNA Expression | 60 |
| VI. | STATISTICAL ANALYSIS | 62 |
| VII. | RESULTS | 63 |
| A. | Demographic, laboratory investigations, and clinical features of the patients..... | 63 |
| B. | MicroRNAs expression profiles by qPCR | 65 |
| C. | Diagnostic performance of circulating MicroRNAs in predicting HCC..... | 68 |

| | | |
|-------|--|-----|
| D. | Correlations | 72 |
| VIII. | DISCUSSION | 75 |
| IX. | CONCLUSION..... | 82 |
| X. | FUTURE PERSPECTIVES..... | 83 |
| XI. | REFERENCES | 84 |
| XII. | APPENDIX..... | 101 |
| A. | Copyright Clearances & Permissions..... | 101 |
| B. | Generic Consent Form – Adult | 111 |
| C. | Institutional Review Board (IRB) | 113 |
| i. | The American University in Cairo | 113 |
| ii. | Theodor Bilharz Research Institute | 114 |

LIST OF TABLES

| | |
|--|----|
| Table 1. The assay identifications representing the primers and probes for the 8 microRNAs... | 61 |
| Table 2. Demographic and laboratory data of all patients and controls..... | 64 |
| Table 3. The qPCR expression levels of the 8 serum microRNAs in the four study groups..... | 65 |
| Table 4. Area Under the Curve (AUC), Confidence Interval, and p-values for all 8 circulating miRNAs..... | 68 |
| Table 5. The sensitivity and specificity of the 8 microRNAs..... | 69 |
| Table 6. The correlation between miR-16 and miR-34a in the three patient groups..... | 72 |
| Table 7. The correlation between miR221, miR-122a, and miR-125a in the three patient groups..... | 73 |
| Table 8. The correlation between miR139, miR-145, and miR-199a in the three patient groups..... | 74 |

LIST OF FIGURES

| | |
|--|----|
| Figure 1. Distribution of HCV Genotypes..... | 17 |
| Figure 2. Global Prevalence of HCV..... | 17 |
| Figure 3. Prevalence of HCV in Egypt..... | 18 |
| Figure 4. The synthesis and function of MicroRNAs..... | 22 |
| Figure 5. Worldwide liver cancer incidence in 2008..... | 27 |
| Figure 6. Incidence of liver cancer in Egypt..... | 28 |
| Figure 7. The <i>miR-34</i> family as a facilitator of tumor suppression by p53..... | 37 |
| Figure 8. A detailed structure of the genomic loci of human <i>miR-34a</i> and <i>miR-34b/c</i> genes..... | 37 |
| Figure 9. MiR-34 regulation in cancer..... | 38 |
| Figure 10. MiR-34a regulation..... | 39 |
| Figure 11 MiR-221 Expression..... | 41 |
| Figure 12. Kaplan-Meier survival curves of HCC patients..... | 41 |
| Figure 13. MiR-221 Regulation..... | 42 |
| Figure 14. MiR-16 Regulation..... | 45 |
| Fig. 15. MiR-122 is a crucial regulator of liver development and disease..... | 48 |
| Figure 16. MiR-125 Targets..... | 50 |
| Figure 17. The down-stream targets of miR-145 and its upstream regulation..... | 53 |
| Figure 18. Box Plots- Part 1..... | 66 |
| Figure 19. Box Plots- Part 2..... | 67 |
| Figure 20. ROC Curves- Part 1..... | 70 |
| Figure 21. ROC Curves- Part 2..... | 71 |

LIST OF ABBREVIATIONS

| | |
|----------------|--|
| ADAM10 | A Disintegrin And Metalloprotease 10 |
| ADAM17 | A Disintegrin And Metalloprotease 17 |
| AFP | α -Fetoprotein |
| AFP-L3 | Lens Culinaris Agglutinin-reactive AFP |
| Ago2 | Argonuate |
| ALT | Alanine Aminotransferase |
| ANGPTL2 | Angiopoietin Like 2 |
| ANOVA | Analysis of Variance |
| AP2a | Activating Protein 2 alpha |
| AST | Aspartate Aminotransferase |
| AUC | Area Under the Curve |
| BBC3 | BCL2 Binding Component 3 |
| BCDIN3D | BCDIN3 Domain containing RNA methyltransferase |
| BCL2 | B cell CLL/lymphoma 2 |
| BCLC | Barcelona Clinic Liver Cancer |
| BMF | Bcl2 Modifying Factor |
| BRCA1 | Breast Cancer gene 1 |
| C/EBP- β | CCAAT/Enhancer-Binding Protein beta |
| CCL2 | Chemokine (C-C motif) Ligand 2 |
| CDK | Cyclin Dependent Kinase |
| CDKN1C/p57 | Cyclin-Dependent Kinase Inhibitor 1C/p57 |
| CHC | Chronic Hepatitis C |
| CI | Confidence Interval |
| CLD | Chronic Liver Disease |
| CLL | Chronic Lymphocytic Leukemia |
| c-MET | cellular Mesenchymal to Epithelial Transition factor |
| c-Myc | MYC proto-oncogene |
| CpG | CG islands |
| CT | Cycle Threshold |
| CULT1 | Cut-Like Homeobox 1 |
| DCP | Des- γ -Carboxyprothrombin |
| DDX6 | DEAD-box helicase 6 |
| DGCR8 | DiGeorge syndrome Critical Region gene 8 |
| EDHS | Egyptian Demographic Health Survey |
| EGF | Epidermal Growth Factor |
| EGFR | Epidermal Growth Factor Receptor |
| ELISA | Enzyme-Linked Immunosorbent Assay |
| EMT | Epithelial Mesenchymal Transition |
| FoxO1/3 | Forkhead box protein O1/3 |
| FSCN1 | Fascin actin-bundling protein 1 |
| GP73 | Golgi protein 73 |
| GPC3 | Glypican-3 |
| GWAS | Genome-Wide Association Study |
| HBsAg | Hepatitis B surface Antigen |

| | |
|----------------|---|
| HBV | Hepatitis B Virus |
| HCC | Hepatocellular Carcinoma |
| HCV | Hepatitis C Virus |
| HMGA2 | High Mobility Group AT-Hook 2 |
| HNF | Hepatocyte Nuclear Factor |
| Ig | Immunoglobulin |
| IGF | Insulin-like Growth Factor |
| IGF1R | Insulin-Like Growth Factor Type 1 Receptor |
| IRB | Institutional Review Board |
| IRS-1 | Insulin Receptor Substrate 1 |
| KO | Knock-out |
| KRAS | Kirsten Rat Sarcoma |
| LC | Liver Cirrhosis |
| LETFs | Liver-Enriched Transcription Factors |
| LOH | Loss of Heterozygosity |
| LS | Liver Stiffness |
| MELD | Model for End-Stage Liver Disease |
| MIF | Merthiolate-Iodine-Formaldehyde |
| MiRNA | Micro RNA |
| MOH | Egyptian Ministry of Health |
| mRNA | messenger Ribonucleic Acid |
| MUC1 | Mucin 1 |
| NAFLD | Non-Alcoholic Fatty Liver Disease |
| NF- κ B | Nuclear Factor-Kappa B |
| NPV | Negative Predictive Value |
| NRAS | Neuroblastoma Rat Sarcoma |
| OCT4 | Organic Cation/Carnitine Transporter 4 |
| p53RE-2 | p53 response elements-2 |
| PBS | Phosphate Buffer Saline |
| PCR | Polymerase Chain Reaction |
| PDE2A | Phosphodiesterase 2A |
| PDTC | Pyrrrolidine Dithiocarbamate |
| PPV | Positive Predictive value |
| Pri-miRNA | Primary miRNA |
| qPCR | Quantitative Polymerase Chain Reaction |
| RAN | Ras-related Nuclear Protein |
| RISC | RNA-Induced Silencing Complex |
| RLC | RISC Loading Complex |
| ROC | Receiver Operating Characteristics |
| RREB1 | Ras Responsive Element Binding Protein 1 |
| RT | Reverse Transcription |
| RT-PCR | Reverse Transcriptase-Polymerase Chain Reaction |
| SCCA | Squamous Cell Carcinoma Antigen |
| SMMC-7721 | Human Hepatoma Cells |
| SOX2 | SRY-box 2 |
| SP1 | Specificity Protein 1 |

| | |
|-------|--|
| SPSS | Statistical Package for the Social Science |
| SRF | Serum Response Factor |
| TACE | Transcatheter Arterial Chemoembolization |
| TBRI | Theodor Bilharz Research Institute |
| TCF-4 | Transcription Factor 4 |
| TEMs | TIE2 Expressing Monocytes |
| TIE2 | Ig and EGF homology domains 2 |
| TNM | Tumor, Node, and Metastasis |
| TRBP | Transactivation Response RNA Binding Protein |
| UTR | Untranslated Region |
| VEGF | Vascular Endothelial Growth Factor |
| WHO | World Health Organization |
| Wnt1 | Wingless/integrated1 family member |
| XPO5 | Exportin-5 |
| ZEB1 | Zinc Finger E-box Binding Homeobox 1 |

I. ABSTRACT

Introduction: The prevalence of hepatocellular carcinoma (HCC) in Africa is higher compared to the rest of the world due to the high incidence of chronic infection with hepatitis C virus (HCV). In Egypt, HCV infection is the leading cause for the high HCC incidence, which is usually diagnosed at late stages. Due to the absence of reliable and accurate biomarkers for early detection of liver cancer, circulating microRNAs have recently emerged as great candidates for early diagnosis of HCC. These small non-coding RNA molecules are responsible for regulating gene expression and RNA stability. Therefore, the aim of this study is to investigate the potential of liver-specific circulating microRNAs as an accurate non-invasive diagnostic tool for the early detection of HCV-induced HCC.

Methods: Eight main miRNAs (miR-16, miR-34a, miR-122a, miR-125a, miR-139, miR-145, miR-199a, and miR-221) were selected due to their expression patterns in HCC as well as their contribution to the development of hepato-carcinogenesis. A total of 165 patients were enrolled in this study, from which serum samples were collected and categorized into four main patient groups: 42 chronic hepatitis C (CHC) without cirrhosis, 45 CHC with cirrhosis (LC), 38 HCC with HCV patients, and 40 healthy controls. The expression profile of the eight miRNAs was analyzed using TaqMan real-time reverse transcription-polymerase chain reaction. Additionally, the conventional markers for HCC α -fetoprotein (AFP) and des- γ -carboxyprothrombin (DCP) were measured using commercial kits.

Results: Serum levels of miRNA-122a, miRNA-125a, miRNA-139, miRNA-145 and miRNA-199a were significantly lower ($p < 0.01$) in HCC than in both CHC and LC groups. On the other hand, no significant difference was shown in the expression of miR-16, miR-34a, and miR-221 between the CHC, LC, and HCC groups. MiR-16, miR-34a, and miR-221 were significantly elevated in the HCC group compared to the control group. MiR-122a showed the highest specificity and sensitivity, followed by miR-125a, which had the second highest specificity, indicating its significance in diagnosis.

Conclusions: The results indicated that measurement of serum levels of miR-122a, miR-125a, miR-139, miR-145, and miR-199a can help to differentiate HCC from CHC and LC. Measurement of serum levels of miR-16, miR-34a, and miR-221 were shown to have a prognostic value. Highly significant correlation was established between different miRNAs within the same patient group or between two different groups, indicating a great diagnostic value for the early detection of HCC. MiR-122a had the highest specificity and sensitivity, indicating that serum miR-122a might serve as a novel and potential non-invasive biomarker for HCV-induced HCC.

II. INTRODUCTION

The significance of reliable biomarkers is usually illustrated by their usefulness during the course of a certain disease. In other words, biomarkers are evaluated based on their ability to be easily detected at the early onset of the disease, their efficacy in risk classification, and their sensitivity and specificity for disease progression and prognosis (Schöler *et al.*, 2010). A biomarker is defined as a molecule that can be measured and assessed, one that indicates the proper functioning of biological processes, normal pathologies, or the pharmacological response to therapeutic drugs. Therefore, a reliable and accurate biomarker must lack limitations such as low sensitivity and specificity, low predictive power, and robustness, in addition to exerting noninvasiveness characteristics (Schöler *et al.*, 2010).

In 1993, Lee *et al.* was the first to discover the small noncoding RNA lin-4 in *Caenorhabditis elegans*, which is now known to be the founding member of 17341 annotated mature microRNAs (miRNAs) in 142 species, out of which 1048 are human mature miRNAs (Lee, Feinbaum, & Ambros, 1993; Wang, Chen, & Sen, 2016). Approximately 20% of all annotated miRNAs are highly conservative between organisms like *C. elegans* and *Homo sapiens*. MiRNAs are assumed to target more than 60% of the human genes, hence their high abundance in mammalian cells. Several research groups have illustrated the deregulation of miRNAs in various pathological processes, which was evident in the development of many diseases as well as malignancies (Schöler *et al.*, 2010).

Measuring the levels of circulating miRNAs to be used as biomarkers for malignancies has recently been researched and investigated. This diagnostic approach shows a lot of promise due to the high stability of miRNAs in human formalin-fixed tissue, serum, and plasma, in addition to their tissue specific expression pattern shown in human malignancies (Qu *et al.*, 2011 & Barger *et al.*, 2016). The hepatocellular carcinoma (HCC) conventional biomarkers are usually able to detect large tumors, which was evident with the relatively high sensitivity when 3 HCC biomarkers were used to detect HCC in patients with large tumors. However, for an aggressive cancer such as HCC, early detection is key to a better therapeutic response and prognosis (Qu *et al.*, 2011).

A microarray chip identifying the global normal levels of each member of the miRNome has been developed in order to enable the comprehensive and efficient profiling of all miRNA genes (Liu *et al.*, 2004). With more research being conducted on the subject, more technologies became available, such as quantitative reverse transcription PCR, macroarrays, and bead-based flow cytometric miRNA expression. Together, these technologies have illustrated the differential expression of human miRNAs in tissues and helped in identifying crucial miRNA genes that play key roles in the development of human diseases (Aqeilan *et al.*, 2010). Researchers have been working in the hope of identifying unique miRNA signatures in human tumors that will help in better understanding cancer pathways and carcinogenesis in general, thus facilitating the proper design of effective diagnostic, therapeutic, and prognostic tools. Number of miRNAs were shown to play a crucial role in cancer development. MiRNAs that are found to be upregulated in tumors function as oncogenes, while other miRNAs have been described as tumor suppressors due to their loss or down-regulation. Moreover, some miRNAs have been identified for their function in metastasis and angiogenesis (Aqeilan *et al.*, 2010).

III. LITERATURE REVIEW

The liver is known to be the largest internal organ, it is divided into two main lobes, right and left, and it is located under the right ribs and beneath the right lung, with a weight of approximately three pounds. It is a major vascular organ that receives approximately up to 25% of the entire cardiac output, which is substantially more than the rest of the body's organs combined. It has two blood supplies divided between the hepatic artery, which is responsible for 25% to 30% of the blood supply to the liver, and the portal vein which supplies the other 70% to 75% (Abdel-Misih & Bloomston, 2010). The liver has several significant functions that support other organs, impacting all physiologic systems. One of the main liver functions is metabolism and protein synthesis, in addition to metabolizing amino acids, lipids, carbohydrates, and vitamins. The liver also performs the crucial function of detoxifying the systematic circulation through the removal of pathogens and exogenous antigens (Bogdanos *et al.*, 2013). It has a significant immunological function, since its reticuloendothelial ability is responsible for phagocytosis and clearance of endotoxins and microorganisms from the portal blood. Bile secretion is a crucial end point of liver function; hence bile production immediately stops when liver perfusion is halted. The unique location of the liver as well as its special vasculature allows it to perform the degradation of waste products and toxins (Hoekstra *et al.*, 2013).

A. Hepatitis C Virus

Hepatitis C infection is a disease that infects the liver as a result of hepatitis C virus (HCV) infection, an RNA virus discovered in 1989 that belongs to the *Flaviviridae* family. HCV infection leads to acute hepatitis C, which develops into a chronic infection in 50-80% of HCV patients. HCV chronic infection activates a chronic inflammatory disease response, which leads to the development of liver fibrosis, cirrhosis, and hepatocellular carcinoma (Manns *et al.*, 2017). The HCV virions are enveloped in a lipid bilayer with a diameter of 45-65 nm. The non-icosahedral nucleocapsid is located inside the envelope, and is made up of the positive-strand RNA as well as several copies of the basic HCV core protein (Penin, Dubuisson, Rey, Moradpour, & Pawlotsky, 2004). Phylogenetic analyses of HCV strains collected from different geographical regions revealed that HCV has seven different genotypes, thus making it a very heterogeneous virus. Additionally, HCV genotypes include multiple subtypes that are

represented by lower-case letters. The severity of the disease as well as the response to antivirals depend on the genotype (Figure 1) (Simmonds, 2013).

The global prevalence of HCV patients who are positive for anti-HCV antibodies was estimated to be 1.6%, which is equivalent to approximately 115 million patients (Gower, Estes, Blach, Razavi-Shearer, & Razavi, 2014). However, not all these individuals currently have HCV; some have cleared the virus after receiving treatment or spontaneously. Therefore, the global prevalence for patients with HCV RNA is approximately 71 million patients. This incidence is based on mega epidemiological studies that have been conducted in 100 countries. Global statistical data is limited since the HCV prevalence is only reported by 29% of the low-income countries and 60% of high-income countries (The Polaris Observatory HCV Collaborators, 2017). The prevalence of HCV infection varies globally, in which the countries with the highest prevalence are those with highest rates of iatrogenic infections. Iatrogenic infection is the major risk factor for the high prevalence of HCV in countries like Gabon, Nigeria, Egypt, Mongolia, Georgia, and Uzbekistan, where the prevalence is >5% in the adult population (Figure 2) (Gower, Estes, Blach, Razavi-Shearer, & Razavi, 2014).

The percentage of the global HCV infection in Western countries is small compared to that of countries like Russia, China, Egypt, India, and Pakistan where half of the total viraemic HCV infections is located (Manns *et al.*, 2017). In Egypt, the high prevalence of HCV is attributed to the schistosoma intravenous injections in the 1960-1970s (Figure 3) (Arafa *et al.*, 2005; Ministry of Health and Population, El-Zanaty and Associates, & ICF International, 2015). Intravenous injections of anti-schistosomal therapy were nationwide under the supervision of the Egyptian Ministry of Health (MOH) and the World Health Organization (WHO). An average of 250,000 patients received more than 2 million injections annually. Approximately 36 million injections were given to >6 million patients over a period of 18 years, in which the majority of needles and syringes were not properly sterilized or disposed (Frank *et al.*, 2000; Rao *et al.*, 2002).

In Egypt, HCV infection is the major cause of liver diseases, such HCC. Approximately 1-5% of cirrhotic patients develop liver cancer, in which 3-6% may decompensate during a period of 20-30 years. One year after decompensation the risk of death is 15-20% (Westbrook & Dusheiko, 2014). A systematic review based on 13 studies that included 2,386 patients

demonstrated that the annual percentage of death/transplantation, decompensation, and HCC among compensated HCV cirrhotic patients is 4.58%, 6.37%, and 3.36%, respectively (Alazawi, Cunningham, Dearden, & Foster, 2010).

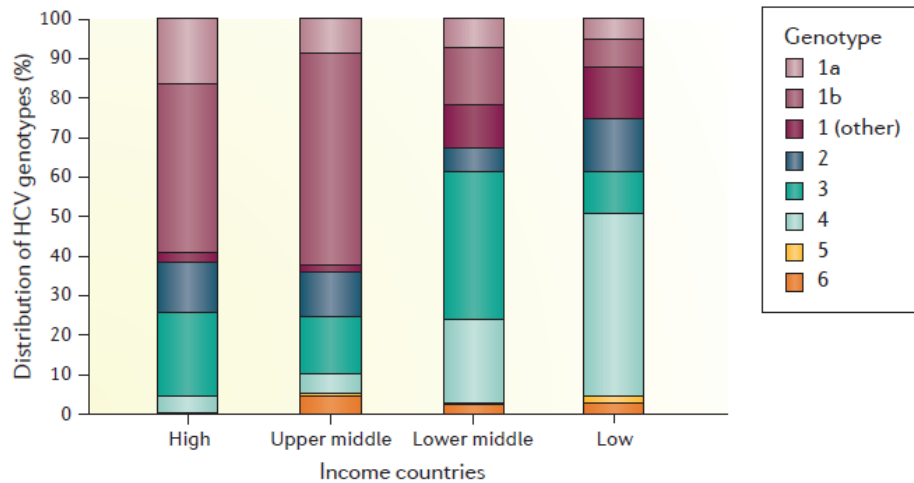

Figure 1. Distribution of HCV Genotypes. Six of the seven genotypes are shown here according to their distribution, which is different between countries based on the categories of the World Bank income. In Europe, the Americas, Australia, Central and East Asia, and New Zealand, genotype 1 is shown to be the most prevalent. Genotype 4 is the most predominant genotype in Egypt and Central sub-Saharan Africa, while genotype 3 is predominant in India and Pakistan. In South Africa, genotype 5 is responsible for more than one-third of HCV infections, while South East Asia is where genotype 6 is most commonly found. Adapted with permission from Manns *et al.*, 2017.

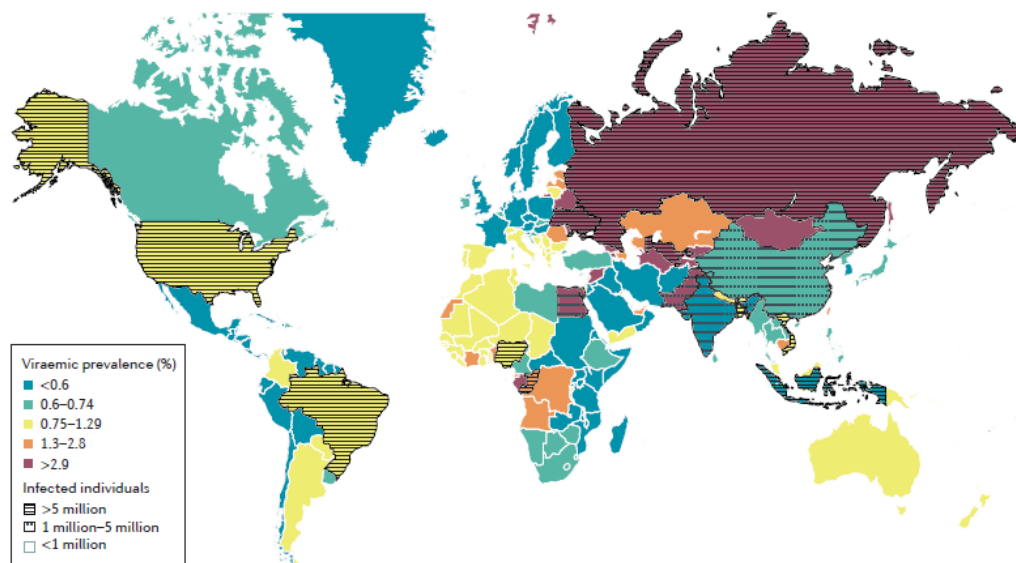

Figure 2. Global Prevalence of HCV. A geographical representation of the prevalence of viraemic hepatitis C virus (HCV) and the estimated total HCV infections per country. Adapted with permission from Manns *et al.*, 2017.

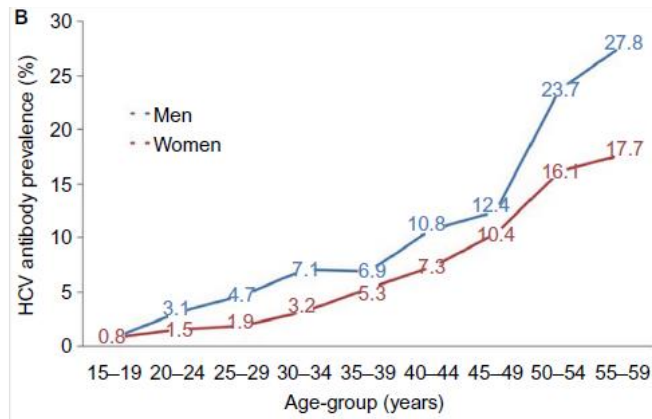

Figure 3. Prevalence of HCV in Egypt. The percentage among men and women in Egypt with hepatitis C antibody in 2015. Adapted with permission from Gomaa *et al.*, 2017.

B. Fibrosis and Cirrhosis

Over the past few decades, liver fibrosis has evolved from being a laboratory discipline into a field of significant clinical relevance to hepatologists. This progress not only reflects the growing understanding of fibrosis molecular basis, but also of its natural history as well as the detection methods of chronic liver diseases (Friedman, 2003). Such advances have illustrated that cirrhosis can be changed, in which antifibrotic therapy can greatly change the management and prognosis of liver disease patients. Cirrhosis is known as the final stage of fibrosis of the hepatic parenchyma as a result of nodule formation as well as the change in hepatic functions (Friedman, 2003).

Fibrosis and cirrhosis are defined as the progression of a continuous wound healing response to chronic liver disease from different etiologies like viral, drug induced, cholestatic, autoimmune, and metabolic diseases. The clinical symptoms of cirrhosis usually range from no sign of symptoms to liver failure, which is usually determined by the nature and the extent of the liver disease etiology in addition to the magnitude of the hepatic fibrosis (Fattovich *et al.*, 1997). Approximately 40% of cirrhotic patients remain asymptomatic for more than a decade; however, rapid deterioration is unavoidable as soon as complications such as encephalopathy, ascites, or variceal hemorrhage start to develop. Patients who suffer such complications have a 50% 5-year mortality, in which around 70% of them are as a result of the liver disease (Fattovich *et al.*, 1997). Cirrhosis affects hundreds of millions of individuals around the world where it is the most

common non-malignant cause of death among digestive and hepatobiliary diseases in the United States (El-Serag & Mason, 2000; Befeler & Di Bisceglie, 2002).

The molecular makeup of the cirrhotic scar tissue is the same regardless of the underlying liver disease, it is composed of the constituents of the extracellular matrix, glycoproteins, collagen types I and III, and sulfated proteoglycans (Schuppan *et al.*, 2001). Over time, these scar components accumulate due to the increase in their deposition in the liver. Although the most visible form of scarring is the cirrhotic bands surrounding nodules, it is in fact the accumulation of matrix molecules in the subendothelial space of Disse that results in the deterioration of liver function (Friedman, 2003).

C. Hepatocellular Carcinoma (HCC)

Hepatocellular carcinoma is categorized worldwide as the third most common cause of cancer-related death as well as the major cause of deaths among patients suffering from liver cirrhosis (Tinkle & Haas-Kogan, 2012). Additionally, it is the fifth most common cancer type in men and the seventh for women worldwide. The incidence of HCC in men is two to four times higher than it is in women. HCC is usually presented around the age of 40 years, where it reaches its peak at the age of 70 years (Ding & Wang, 2014). Every year, more than half a million individuals are diagnosed with HCC worldwide, with an estimate of 20,000 new cases only in the United States. Around 85% of the burden of the disease falls on the shoulders of developing countries. The highest reported rates of hepatitis B virus (HBV) are in Southeast Asia and sub-Saharan Africa (El-Serag, 2011). HCC resulting from hepatitis C virus is becoming a fast-rising cause of cancer related deaths in the United States, in which the incidence has seen to be tripled during the past two decades while the 5-year survival rate still remained less than 12% (El-Serag, 2011). Additional risk factors for HCC include non-alcoholic fatty liver disease, high alcohol intake, alpha1-antitrypsin deficiency, Wilson's disease, hemochromatosis, and autoimmune hepatitis. Aside from the genetic factors, the majority of HCC cases result from chronic inflammation and persistent liver injury (Ding & Wang, 2014). Over the past decades, there has been evidence demonstrating that hepatitis B and C viral proteins can directly stimulate oncogenic effects or increase the risk of hepatocellular transformation with hyperproliferative response as a result of chronic inflammation. Thus, regardless of the etiology, a proliferative

tissue and inflammatory microenvironment is a common preneoplastic liver feature (Ding & Wang, 2014). Symptoms related to HCC are typically absent, patients usually show symptoms related to cirrhosis, which is a condition found in 80-90% of HCC patients. As a result, the majority of HCC patients are diagnosed with an advanced stage of the disease, which excludes potentially curative approaches. This partially led to the 5-year overall rate of survival of 12% and an average survival post diagnosis of 6 to 20 months (Tinkle & Haas-Kogan, 2012). The absence of accurate diagnostic tools for early HCC detection as well as curative therapy, resulted in very poor patient prognosis. HCC morbidity and mortality are almost the same due to the fact that the majority of HCC patients are diagnosed at late stages of the disease where the cancer is significantly advanced for good therapeutic options (Ding & Wang, 2014).

Approximately more than 700,000 HCC cases are diagnosed annually all over the world, with more than 600,000 deaths yearly due to HCC (Dhanasekaran *et al.*, 2012). When HCC is presented with symptoms it is usually associated with nonspecific illnesses, such as pain in the right upper abdominal area, malaise, early satiety, and weight loss. The presentation of encephalopathy, jaundice, ascites, or variceal bleeding in patients suffering from liver cirrhosis raises doubts of HCC. It is rare that patients may complain of hypotension, severe abdominal pain and distension, and a severe drop in hematocrit as a result of the tumor rupturing as well as intraperitoneal bleeding. HCC is known to be linked to several paraneoplastic syndromes that lead to cutaneous manifestations, erythrocytosis, hypercalcemia, hypoglycemia, severe watery diarrhea, and hypercholesterolemia. The most common sites of metastasis resulting from HCC include the adrenal gland, bone, lung, and regional lymph node regions (Tinkle & Haas-Kogan, 2012).

D. MicroRNAs:

The potential of miRNAs was recognized shortly after their discovery in 1993 in *C. elegans*, in which their significance in diagnosis and therapy was thoroughly investigated. MiRNAs regulate the process of protein translation through binding to the complementary sequences in the 3' untranslated region (UTR) of the target mRNA. Currently, there are over 2,500 human miRNAs in the miRBase, a database containing all the published miRNAs and their annotation. (Hayes, Peruzzi, & Lawler, 2014). The miRNA names in miRBase are represented as has-mir-

121, in which the first three letters refer to the organism from which the miRNA was identified. In the database and the literature, the mature miRNA is referred to as miR-121, while the miRNA gene is referred to as mir-121. Different precursor sequences as well as genomic loci expressing the same mature sequences are referred to as hsa-mir-121-1 and hsa-mir-121-2. On the other hand, letter suffixes indicate mature sequences that are closely related, such as hsa-miR-121a and hsa-miR-121b. Finally, in the case of insufficient data it might be challenging to determine which sequence is the predominant one; therefore, 5p (from the 5' arm) or 3p (from the 3' arm) is denoted after the miRNA identification number (ex. miR-142-5p) (Hikmet, Reyyan, Melda, & Burcu, 2016).

E. Synthesis of MiRNAs:

The synthesis of miRNA is mainly divided into two stages, one that takes place inside the nucleus, while the other takes place in the cytoplasm (Chu *et al.*, 2014). The majority of miRNAs are transcribed by RNA polymerase II from intergenic regions, introns and exons. The first RNA transcript is an RNA precursor known as primary miRNA (pri-miRNA). Usually the pri-miRNA ranges in length from 200 to several thousand nucleotides, which forms a highly structured stem loop (Figure 1). After that, 'Drosha', the cellular RNase III enzyme, cleaves the stem loop structure with the assistance of, the cofactor DiGeorge syndrome critical region gene 8 (DGCR8) in vertebrates and 'Pasha' in invertebrates (Lee *et al.*, 2003; Denli, Tops, Plasterk, Ketting, Hannon, 2004; & Gregory *et al.*, 2004). The cleavage results in an RNA hairpin intermediate structure approximately 70 nucleotides in size, called the precursor-miRNA (pre-miRNA) that has two distinguished nucleotide 3' overhang. The following step of the synthesis of miRNA is the exportation of the pre-miRNA hairpin from the nucleus by a heterodimer made of exportin 5 and the GTP bound form of cofactor Ras-related nuclear protein (RAN) that identifies and binds the two 3' overhand ends of the pre-miRNA (Yi, Qin, Macara, & Cullen, 2003; Lund, Guttinger, Calado, Dahlberg, & Kutay, 2004). After being transferred to the cytoplasm, another cellular RNase III enzyme known as Dicer, attaches to the structured RNA along with cofactor Transactivation response RNA binding protein (TRBP) to start a second cleavage. After the cleavage the resulting product is a double stranded RNA, with two nt 3' overhang about 17-22 bp long. Out of the dsRNA, one stays attached to the Dicer for the formation of the mature miRNA while the remaining strand usually degrades (Gupta *et al.*, 2014).

Finally, the mature single stranded miRNA is generated with the help of helicases like RCK/p54 or Gemin3. The RISC loading complex (RLC) is formed by the association of TAR RNA binding protein or TARBP2 (TRBP), Argonaute 2 (Ago2), and Dicer (Chu *et al.*, 2014). One of the most important components in the RISC complex is the Argonaute-2 (Ago-2) protein, which is a catalytically active ribonucleoprotein (Liu *et al.*, 2004; Meister *et al.*, 2004). The mature miRNA attached to the active RISC complex binds at 3' UTR of the target sites of a certain mRNA resulting either in immediate inhibition of translation or the degradation of the target mRNA by the Ago2 protein in the RISC complex (Figure 4). In the case of vertebrates, only partial complementary miRNA is needed to recognize the mRNA targets; however, it is crucial to have high complementarity of miRNA within the “seed sequence”, which is a region in the mature miRNA located in nucleotides 2-8 (Gupta *et al.*, 2014).

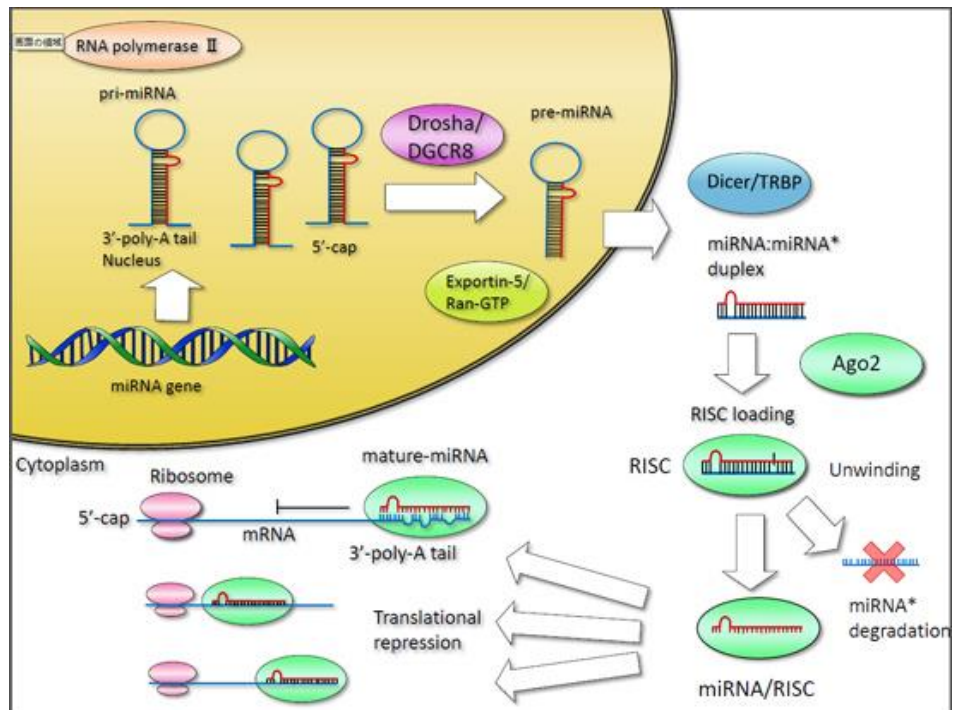

Figure 4. The synthesis and function of MicroRNAs. The transcription of microRNA (miRNA) genes is carried out by RNA polymerase II. The primary miRNA transcripts are processed into pre-miRNA by the microprocessor complex (Drosha/DGCR8). After that the pre-miRNA is exported from the nucleus to the cytoplasm by exportin-5 and Ran-GTP, then processed into a RNA duplex by ribonuclease Dicer with the help of TRBP. The final product is 22 bp dsRNA, in which one strand stays bound to dicer that later form the mature miRNA, while the other strand gets degraded. Finally, the remaining strand gets associated with RNA-induced silencing complex (RISC) and argonaute 2 (Ago2), which targets gene silencing by either cleavage or translation inhibition. Different proteins or protein complexes are shown in colored ovals. RNA is depicted by red and blue lines. Adapted from Hayes & Chayama, 2016, open access article, no permission.

i. Key enzymes in the processing stage of pri-miRNA to pre-miRNA:

As shown by several research studies, Drosha and DGCR8 are considered to be key enzymes in regulating the processing from pri-miRNA to pre-miRNA in different kinds of malignant cells. However, for some miRNAs the processing from pri-miRNA to pre-miRNA does not depend on the complex DGCR8 and Drosha. In the case of HCC, both Drosha and DGCR8 were shown to be over-expressed in the tumor cells (Chu *et al.*, 2014). According to Liu *et al.* out of the genes involved in the synthesis of miRNAs, DROSHA was found to be the most differentially expressed in HCC induced by HBV infection (Liu *et al.*, 2011). Similarly, unusual expression of Drosha can be seen in breast, ovarian, and cervical cancers, indicating the involvement of Drosha in different types of tumors. Few studies have shown HBV can inhibit the activity of Drosha, in which it inhibits its promoter activity through HBx and hence down-regulating the expression of Drosha, also the transcription factors SP1 and AP2a might help in facilitating the down-regulation (Chu *et al.*, 2014).

ii. Key enzymes involved in the nuclear exportation of pre-miRNA:

The nuclear exportation of pre-miRNA primarily depends of XPO-5, whose defect in cancerous cells may lead to the down-regulation of the global mature miRNAs. It was found that in many cancers the pre-miRNAs are retained inside the nucleus; therefore, a gene mutation in the nuclear transporter of the pre-miRNAs might be a reason for human cancers (Chu *et al.*, 2014). As a matter of fact, XPO5-inactivating mutations are always identified in several human tumors, implying that XPO5 might be considered a haplo-insufficient tumor-suppressor gene. During the entry of the cell cycle, elevation in miRNA is crucial in order to control gene expression. It was illustrated by Lwasaki *et al.* (2013) that XPO5 is induced by a post-translational mechanism that is PI3K-dependent, in which the suppression of XPO5 interferes with the miRNA elevation resulting in a defected cellular proliferation at the G1/S transition. Additionally, XPO5 is not only responsible for the exportation of pre-miRNA from the nucleus to the cytoplasm, but also for the exportation of other non-miRNA molecules (Wild *et al.*, 2010).

iii. Key enzymes involved in regulating the processing from pre-miRNA to mature miRNA:

As mentioned before, Dicer is the enzyme responsible for dicing and creating mature miRNA. The majority of miRNAs are known to be Dicer dependent. However, some scientists have reported that in the case of miR-451, its dicing and maturation actually depends on Ago2 rather than Dicer (Cheloufi *et al.*, 2010; Cifuentes *et al.*, 2010). In humans, the gene *Dicer1* codes for Dicer, which then functions as a haplo-insufficient tumor suppressor gene (McCarthy, 2010).

F. Epidemiology:

Even though HCC is known to be the most common primary hepatic tumor globally, there are major differences in its incidences among different parts of the world, with the majority of cases found in developing countries. According to the GLOBOCAN report, 746,300 newly diagnosed HCC cases were reported worldwide in 2008, while 659,900 of HCC related deaths were reported in the same year (Figure 5) (Dhanasekaran *et al.*, 2012). Over one million new cases of HCC are diagnosed annually worldwide, making HCC as the fifth most common cancer globally (Raphael *et al.*, 2012). HCC has a high incidence to mortality ratio of 1.07, which categorizes it as the third most common cause of cancer-related deaths around the world. The majority of these cases are found in developing countries where 84% of the total worldwide incidence and 83% of the total deaths have been recorded. The worldwide distribution of HCC cases is parallel to the global incidences of HBV and HCV infections, where the majority of HCC cases are located in the regions where these viral infections are endemic. Generally, HCC illustrates a male dominance, in which it is displayed in two to four times more in males than in females (Jemal *et al.*, 2011).

There are some unusual trends in the worldwide incidence of HCC, for example, the incidence in Asian regions like Korea and China is declining in population-based studies, which is attributed to the high number of vaccinations against hepatitis B as well as the aflatoxin preventive measures. Unlike the declining rates in Asian countries, several regions in the developing world have been showing an increase in the HCC incidence, particularly in Japan and the United States. This acceleration in the HCC incidence is related to large number of adults who showed signs of HCV infections as a result of blood transfusions and intravenous drug use between the period of the 1960s until the 1980s (El-Serag & Mason, 2000). In Egypt, liver

cancer is one of the most common tumors due to the high incidence of HCV infection. In men, both liver and bladder cancers represent approximately 44% of all malignancies, while in women liver and breast cancers represent 45% of all female malignancies (Figure 6) (Ibrahim, Khaled, Nabel, Baraka, & Kamel, 2014). In addition, the rapidly increasing incidence of diabetes, nonalcoholic steatohepatitis (NASH), obesity are suspected to have contributed to the increasing numbers of HCC patients worldwide. However, regardless of the etiology, the main risk factor in the majority (80-90%) of HCC cases worldwide is the existence of the preneoplastic cirrhotic liver. According to the current statistics, the HCC incidence in the United States will continue to increase over the next two or three decades (Dhanasekaran *et al.*, 2012).

G. HCC Molecular Classification:

Great expectations were anticipated from the field of molecular medicine to unravel the mysteries of the molecular pathogenesis of cancer for the great benefit of the patients (Bruix *et al.*, 2014). Biomedical research aimed at achieving several goals, such as easily identifying patients with high risk factors, detecting common oncogenic pathways, and developing the personalized and targeted medicine approach. For various types of cancers goals outlined above have been achieved, however for other types these goals have been marred by a slow rate of progress. The process of carcinogenesis is far more complicated than what is already known due to the abundance of genetic heterogeneity and the difficulty of accurately mapping the numerous genetic pathways (Yap *et al.*, 2012). Other factors which contribute to this complicated process include the changing of genetic information in nature and the need to study cancer pathways in comparison to those of the non-tumor tissue in order to identify the changes in the tumor tissue.

Cancer changes over time as the disease progresses, and therefore, various genetic features important for carcinogenesis differ and develop during metastasis. Since human tissue used for genetic analysis is usually obtained from surgical specimens, this puts restriction on the research since only a relatively small number of patients are studied. The genetic heterogeneity of cancer can be notably intriguing since differences are not only found between patients, but even between nodules in a single patient or with the same nodule (Bruix *et al.*, 2014). For example, Tao *et al.* (2011) carried out whole genome sequencing where three nodules in the same patient were examined in one patient showing two driver mutations in a single nodule as a

result of clonal evolution and separate driver mutations in the other two nodules. Therefore, not only each patient represents a unique cancer signature, but every single tumor nodule might be genetically different from the other within the same individual. Another reason for the genetic variations in HCC is due to the etiology of the liver disease as well as the genetic background of the patient. Even when genetic research identifies oncogenic pathways there is usually several obstacles to target them therapeutically since the current pharmacological technology is more efficient in synthesizing kinase inhibitors than in preventing the protein-protein interactions. For example, despite the extensive research of the WNT/ β -catenin pathways in HCC, they still represent several challenges to be pharmacologically targeted. The dependence of the cancer cell on the intrinsic oncogene mutation for survival is known as oncogene addiction; one of the aims of genetic research is to identify the oncogenic mutations necessary for therapeutic targeting. Due to the difficulty of cancer genetics, the progress that has been made in research so far is not yet enough to unveil the complexity of carcinogenesis in HCC (Sharma & Settleman, 2007).

Number of genome-wide association studies (GWAS) studying the single nucleotide polymorphisms have been carried out, where they identified the affected pathways, such as, inflammation-cytokine-chemokine systems, oxidative stress and detoxifying pathways, iron metabolism, DNA synthesis and repair mechanisms. It has been shown that functional polymorphisms in the epidermal growth factor receptor (EGFR) is associated with an increased risk of HCC (Chan *et al.*, 2011; Nahon & Zucman-Rossi, 2012). In addition, somatic mutations activating telomerase reverse transcriptase promoter have been identified in the cirrhotic preneoplastic macronodules and early stages of HCC, which implicates that these mutations in the liver tissue could be used a diagnostic tool for HCC to identify high risk individuals (Bruix *et al.*, 2014).

As a matter of fact, one of the main obstacles towards HCC treatment is its high risk of recurrence. Expression profiling studies of HCC tissue as well as the non-tumor tissue has provided insight into the high recurrence risk as well as predicted the recurrence of the tumor. Such data showed that the majority of tumor recurrences in the post curative therapy has not metastasized from the original tumor but are actually new tumors originating in the cirrhotic liver. Additionally, another known risk factor for recurrence of HCC is microinvasion, which entails that the genetic signature predicting vascular invasion would help in determining the

patient's risk of recurrence. Currently the alternative approach to predict the recurrence of HCC has been combining pathological, clinical, and gene expression data (Villanueva *et al.*, 2011). A study by Nault *et al.* (2013) showed that the combination of the proliferative molecular expression signature and the pathological data of the satellite nodules could be used to efficiently predict the recurrence of the disease.

Several studies focused on mRNA expression and genome-wide methylation profiling, in which three main pathways were identified, WNT/ β -catenin, a proliferation and a hepatoblastoma-like pathway. However, the molecular signatures that have been identified so far are general and do not overlap with other studies. Thus, although they are informative there is a very small chance that they would be helpful in clinical practice, especially that they have not explained specific and targetable oncogenic pathways. Also, same scenario applies to the genome-wide methylation profiles that have been published so far (Shen *et al.*, 2012). Another approach in the molecular classification of HCC is through analyzing the expression patterns of miRNA, which showed dysregulation of different miRNAs. However, no functional studies have been carried out to illustrate the nature of the miRNA dysregulation (Bruix *et al.*, 2014).

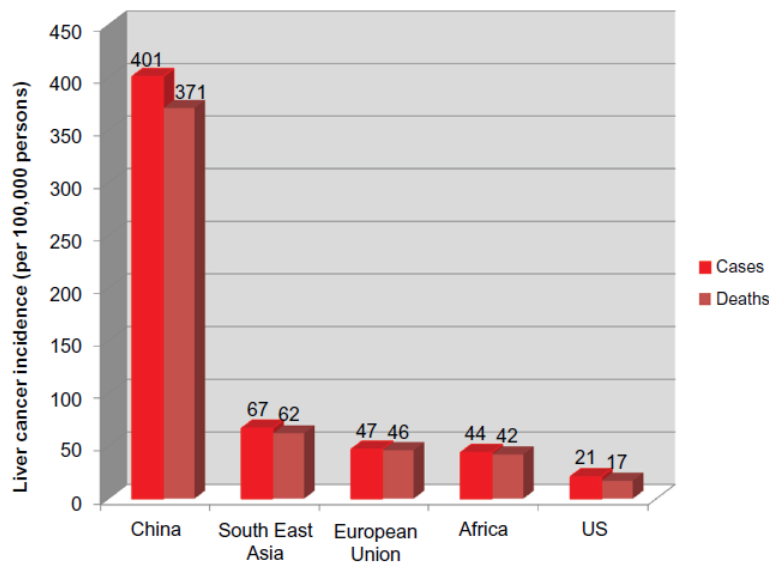

Figure 5. Worldwide liver cancer incidence in 2008. Age-standardized incidence of liver cancer rates in different parts of the world in 2008 according to the International Agency for Research on Cancer, the 2008 GLOBOCAN report. Adapted with permission from Dhanasekaran *et al.*, 2012.

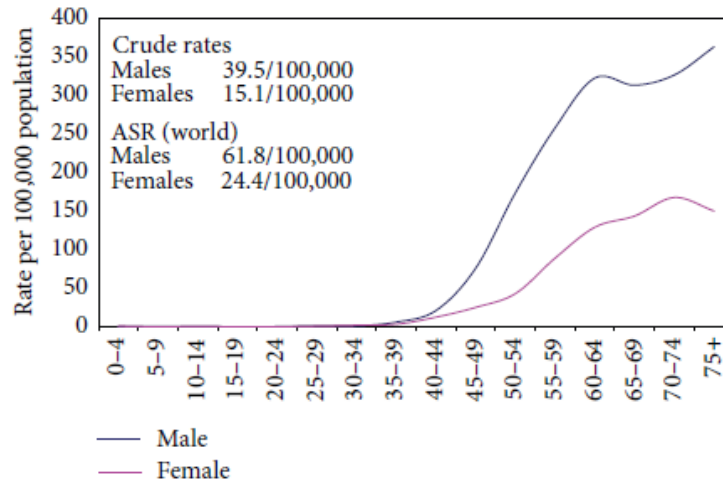

Figure 6. Incidence of liver cancer among in Egypt. The age specific incidence of liver cancer in Egypt 2008-2011. Adapted from Ibrahim, Khaled, Nabel, Baraka, & Kamel, 2014, open access article, no permission.

H. HCC Diagnosis:

Despite the recent advances in treatment options for liver cancer, the survival rate still remains very poor among the majority of liver cancer patients especially those presented at a relatively late stage of the disease (van Meer *et al.*, 2013). Screening of high risk patients who suffer from chronic liver disease might help in detecting HCC at early stages, hopefully leading to decreased mortality rate. However, surveillance and screening remain controversial due to the limited evidence available regarding their efficiency, sensitivity, and the potential risk factors (Lederle & Pocha, 2012; Sherman, Bruix, Porayko, & Tran, 2012). Therefore, new screening strategies are urgently needed in order to tackle severity of HCC.

In order to lower the incidence of HCC, diagnose it early, and establish an efficient epidemiology, both proper screening and surveillance should be applied (Noda *et al.*, 2010). Screening is running a particular test in order to detect a disease in a population that show no symptoms or signs of that diseases, while surveillance is periodically repeating that screening test on the same target population. The main goal of both screening and surveillance is to detect a certain disease before it starts becoming symptomatic, when treatment would be more effective, ultimately decreasing the disease mortality. In case of positive results of screening or surveillance tests there must be a clear protocol to identify true positive cases with a specific diagnostic plan (Giannini *et al.*, 2013).

i. Screening and Surveillance Guidelines:

The aim of surveillance for HCC is to detect small lesions that will respond to curative treatments and hence improve patient overall survival. One of the main guidelines for successful screening and surveillance is the disease being common with significant morbidity and mortality (Giannini *et al.*, 2013). HCC is a very common malignancy worldwide, where its incidence is expected to increase in Western countries as a result of the aging of patients suffering from chronic HCV, which remains as the major etiological factor of HCC in the developed world (El-Serag, 2004 & Kanwal *et al.*, 2011). It has been shown that the rates of incidence and mortality are quite similar worldwide, therefore demonstrating the short term lethality of this tumor especially when diagnosed at late stages of the disease hindering methods of effective treatment. Also for a screening and surveillance program to be successful the target population must be easily identifiable (Bosetti *et al.*, 2008; Bosetti *et al.*, 2009; & Bertuccio *et al.*, 2013). As mentioned before about 90% or more of all HCC patients progress from a cirrhotic liver, which is mainly caused by chronic liver diseases such as HBV and HCV, alcoholism, and non-alcoholic fatty liver disease. These liver diseases can be diagnosed using the patient history and/or serological tests, which would easily identify patients at risk of HCC and in need of surveillance (Fattovich, Stroffolini, Zagni, & Donato, 2004).

Characteristics such as low morbidity, high sensitivity and specificity are critical components of surveillance. According to the American and European guidelines for management of HCC, it is recommended that surveillance should be done by a liver ultrasound examination every 6 months. Such periodical surveillance is expected to have no morbidity, since when the ultrasound is carried out properly it has a relatively high specificity and sensitivity (Bruix & Sherman, 2011; European Association for The Study Of The Liver, 2012). In a meta-regression analysis by Singal *et al.* (2009), it was shown that ultrasound has the ability to detect subclinical HCCs with a 94%-95% sensitivity; however, the sensitivity is only 63% for early HCC detection, while the specificity was usually more than 90%. A semiannual ultrasound is considered an easy non-invasive procedure that is relatively low cost, which makes it possible for the patient to follow (Davila *et al.*, 2010). Therefore, the demand is high for skillful sonographers to perform a reliable HCC surveillance using ultrasound. Additionally, serum alpha-fetoprotein (AFP) has been used as a surveillance tool with an acceptable specificity;

however, it has a low sensitivity for early HCC detection since only 10-20% of early malignancies is presented with high levels of serum AFP. Combining ultrasound and serum AFP shows slight increase in sensitivity of the surveillance test; however, it doubles the cost because of the high number of false positives. In Europe and the United States, it is recommended that patients with a HCC high risk like those suffering from cirrhosis and/or chronic hepatitis, undergo periodical surveillance (Trevisani *et al.*, 2002; Bruix & Sherman, 2011; Sherman, 2011; European Association for The Study Of The Liver, 2012; & Giannini *et al.*, 2012).

ii. Biomarkers for HCC Screening:

The screening for HCC at the advanced or intermediate stage of the disease [according to the system of the Barcelona Clinic Liver Cancer Staging (BCLC)] could have a great significance for the TACE or sorafenib therapy. However, screening should be better in detecting the disease at its very early stages (one lesion ≤ 5 cm or 3 lesions each ≤ 3 cm with no metastasis or angiogenesis), and therefore allowing a better opportunity for potential curative therapy (van Meer *et al.*, 2013). The serological biomarkers are considered cost effective and less physical burden for the patient. Many serological biomarkers have been investigated for early detection of HCC, usually for diagnostic purposes rather than surveillance and screening studies. For decades, AFP has been the most commonly used serological biomarker for HCC detection (van Meer *et al.*, 2013).

Alpha-fetoprotein is a glycoprotein expressed in the fetal hepatocytes or malignant HCC cells. However, AFP is not secreted into the circulation by all HCC cells; in addition, the levels of AFP have been shown to be elevated in chronic liver disease patients without HCC as well as in patients with other types of malignancies (Di Bisceglie *et al.*, 2005). According to a report published by Gupta *et al.* (2003) studying patients with HCC at all stages of the disease with an underlying cirrhotic or non-cirrhotic HCV, AFP remains a weak biomarker for screening even with the highest sensitivity and specificity estimates. With the usual AFP cut-off of 20 ng/ mL, the sensitivity and specificity for HCC detection were 41%-65% and 80%-94%, respectively (Gupta *et al.*, 2003). A recent large case-control study was performed that included 419 HCC cases and 417 cirrhotic controls with different etiologies, in which the efficiency of AFP in early HCC detection was compared with other serological biomarkers, such as lectin-bound AFP and

des-carboxyprothrombin (DCP) (Marrero *et al.*, 2009). In this study, AFP sensitivity and specificity for early detection of HCC were 53% and 90%, respectively, using 20 ng/ mL as the recommended clinical cut-off point. In the receiver operating characteristics (ROC) curve a point with ideal sensitivity and specificity was used as cut-off of 10.9 ng/ mL, in which the sensitivity turned out to be 66% while specificity was 82%. This finding suggested that the usual cut-off point of 20 ng/ mL is too high for the optimum AFP screening (Marrero *et al.*, 2009).

Lectin-bound AFP is another potential serological biomarker for early detection of HCC. Lectin-bound AFP, is one of the three glycoforms of AFP, demonstrated by its reactivity in lectin affinity electrophoresis (Li, Mallory, & Satomura, 2001). A study investigated the accuracy in diagnosis comparing lectin-bound AFP and AFP in patients suffering from cirrhosis as a result of an HCV infection (Sterling *et al.*, 2007). The incidence of HCC at reference point and during a two years was much higher in patients with high levels of lectin-bound AFP than patients with high AFP. In addition, patients with elevated AFP levels had higher levels of lectin-bound AFP, which suggests that the levels of lectin-bound AFP has clinical importance as another test for HCV patients with low AFP levels by categorizing a subgroup of patients with a high chance of HCC (Sterling *et al.*, 2007). Other studies have reported even less encouraging results regarding the accuracy and efficiency of lectin-bound AFP. Numerous of studies have investigated the diagnostic efficiency of a combination of serological biomarkers; however, when AFP and DCP were combined there seemed to be little or no progress in the rates of sensitivity for early HCC detection (van Meer *et al.*, 2013).

DCP is an abnormal protein produced as a result of a defect that is acquired during the post-translational carboxylation of the prothrombin precursor in cancerous hepatocytes (Liebman, 1989). Several studies have investigated the efficiency of DCP as a serological biomarker for early detection of HCC; however, the results were inconclusive (Ishii *et al.*, 2000; Ikoma *et al.*, 2002; Marrero *et al.*, 2003; & Lok *et al.*, 2010). For example, a case-control study with 39 HCC cases and 77 controls, DCP was shown to be more accurate than AFP (Lok *et al.*, 2010). DCP alone has sensitivity and specificity of 74% and 86%, respectively, with a cut-off value of 40 mAU/ mL (Marrero *et al.*, 2009).

Recent studies have suggested new serum biomarkers for early HCC detection, such as the receptor of angiopoietins tyrosine kinase with Ig (immunoglobulin) and EGF (epidermal growth factor) homology domains 2 (TIE2). TIE2 expressing monocytes (TEMs) were recently discovered to be enriched in HCC as well as in other tumors where angiogenesis is essential for tumor development (van Meer *et al.*, 2013). According to Matsubara *et al.* (2013) in a study that included 168 HCV patients, of which 89 had developed HCC registered a significantly higher abundance of TEMs in the peripheral blood independent of the tumor stage. TEMs were also elevated in a separate group of HCC patients without HCV. TEMs were more effective than AFP and DCP in discriminating HCC from cirrhosis or chronic hepatitis (Matsubara *et al.*, 2013). On the other hand, it was shown in another study that circulating and intrahepatic TEMs were elevated in patients who did not develop HCC but had HCV infection (Rodríguez-Muñoz *et al.*, 2011). Although these findings represent a limited cohort of HCV-infected patients, they still might indicate that TEMs expansion and mobilization may not be strictly HCC related, but associated more with chronic liver infection (De Palma, Coukos, & Semela, 2013).

Other research groups studied the role of Glypican-3 (GPC3), which is a surface protein expressed in the majority of HCC cases, yet it is undetectable in the hepatocytes of normal individuals as well as patients who are presented with a benign liver disease (Capurro *et al.*, 2003; Tangkijvanich *et al.*, 2010; & Yasuda *et al.*, 2010). Golgi protein 73 (GP73) is another potential biomarker, which is an amino acid that is usually found in the Golgi complex (van Meer *et al.*, 2013). Marrero *et al.* (2015) showed that the levels of GP73 are elevated in the serum of HCC patients, with a 62% sensitivity for early detection of HCC.

Interleukin-6 (IL-6) a cytokine associated with cell differentiation and growth, is another potential biomarker for HCC that has been investigated. The concentrations of serum IL-6 appeared to be elevated in HCC patients compared to healthy individuals (Hsia *et al.*, 2007 & Porta *et al.*, 2008). The sensitivities of IL-6 for the differentiation between HCC patients and healthy control ranged from 46% to 73%, while the specificities ranged from 87% to 95% (Giannelli *et al.*, 2005 & Hussein *et al.*, 2008). Although extensive research has been conducted aiming to uncover the most reliable HCC biomarkers that would help in the early diagnosis of the disease, there is still a lot of work that needs to be done in order to discover the most specific, sensitive, non-invasive biomarker for HCC diagnosis.

iii. Imaging Techniques for HCC Screening:

Currently, the most commonly used method for surveillance of HCC is ultrasonography (US). The main advantage of US is the lack of invasiveness; however, it is known to be time-consuming, technician-dependent, and relatively expensive (van Meer *et al.*, 2013). In addition, the method is not applicable for an overweight patient. It was shown in a meta-analysis by Singal *et al.* (2009) with 13 studies included, that the combined sensitivities and specificities were 94% for HCC detection at any stage. On the other hand, US was less accurate in detecting the potentially curable early stages of HCC, in which the combined sensitivity was 63%. Another systematic study by Colli *et al.* (2006) showed that US alone is inadequately sensitive for HCC screening. According to this study, sensitivities for HCC detection (all disease stages combined) in the 14 studies included, ranged from 30%-100%, while specificities ranged from 73%-100%. However, it is important to take note that noticeable variability between the studies can be due to the populations tested, the size of the tumors, and/or differences in technicians' experience and skills. Additionally, Singal *et al.* (2009) studied combining AFP with US in a meta-analysis aiming at the early detection of HCC. There was a slight increase in the pooled sensitivities from 63% to 69%; however, it was not statistically significant, which suggests that combining AFP with US is not very effective in HCC screening (van Meer *et al.*, 2013). Clinical evidence suggests that the interval of tumor growth from undetectable to a lesion of 2 cm in diameter usually ranges from 4 to 12 months.

Recently, computed tomography (CT) and magnetic resonance imaging (MRI) are now being used as good tools for HCC screening. However, these imaging techniques are mainly still used to further evaluate cases with abnormal findings from US results in order to determine the extent of the tumor. According to a comprehensive review by Colli *et al.* (2006), spiral CT imaging showed comparable sensitivities and specificities similar to US for HCC detection in patients presented with chronic liver disease. The combined sensitivities for US and spiral CT imaging were 60% and 68%, respectively, while the combined specificities were 97% and 93%, respectively (Colli *et al.*, 2006).

I. MicroRNAs and HCC:

MicroRNAs have been associated with the regulation of cellular processes that are known to be deregulated in cancer, such as proliferation, apoptosis, and differentiation. Changes in the expression of miRNAs in cancer have been demonstrated in several studies, suggesting the significant contribution of miRNAs to the characteristics of the tumor cells (Hermeking, 2010). Additionally, several miRNA-encoding genes have been categorized as either tumor suppressive or oncogenic according to the role they play during cell transformation and altered expression in cancers. MicroRNAs with tumor suppressive ability may act by downregulating the proto-oncogenes products, such as in the case of miRNA family *let-7* that targets the expression of *KRAS*, *HMGA2*, and *NRAS* oncogenes, and it is not expressed in lung tumors (Hermeking, 2010).

i. MiR-34a:

The role of miR-34a has been frequently studied, which revealed its significant role in development of carcinogenesis in many different cancers. In HCC, miR-34a is known to inhibit the invasion and migration of the human HCC cells (Li *et al.*, 2014). In a study by Li *et al.* (2009), the research group highlighted the important role miR-34a plays in regulating the scattering, migration, and invasion of tumor cells. In the study, 19 out of the 25 (76%) HCC human tissue samples showed down-regulation of miR-34a in comparison to adjacent normal tissue (Li *et al.*, 2009). Additionally, normal and HCC tumor tissues of 25 patients showed an inverse correlation between the c-Met-protein and miR-34a. In HepG2 cells, the ectopic expression of miR-34a significantly inhibited the migration and invasion of tumor cells in a c-Met-dependent manner (Li *et al.*, 2009; Dang *et al.*, 2013). Several studies back in 2007, reported that members of the *miR-34* family are considered direct targets of p53, in which their upregulation is seen to induce cell-cycle arrest and apoptosis (Figure 7). In mammals, the *miR-34* family includes three mature miRNAs encoded by two different genes, in which *miR-34a* is encoded by its transcript, while *miR-34b* and *miR-34c* have the same common primary transcript (Figure 8) (Hermeking, 2010). In mice, *miR-34a* is abundantly expressed, where the brain tissue shows the highest expression, while *miR-34b/c* is highly expressed in the lungs. Recent studies demonstrated that the expression levels of *miR-34a* are higher than *miR-34b/c*, except for the lungs where *miR-34b/c* is mainly expressed. Thus, the two *miR-34* genes are considered to have tissue-specific functions (Bommer *et al.*, 2007). It was shown that *miR-34* genes show liver

ectopic expression, which has significant impact on cellular proliferation and survival. For example, the ectopic expression of *miR-34a* and *miR-34b/c* induced cell-cycle arrest at the G₁ phase. Both proliferation and colony formation was inhibited in soft agar due to the expression of *miR-34b/c*. Several studies also showed that the re-expression of *miR-34a* induced apoptosis, and since apoptosis and cell-cycle arrest usually occur upon the activation of p53, it is hypothesized that *miR-34* genes may act as effective mediators of p53 tumor suppression (Chang *et al.*, 2007). The tumor suppressor protein, p53, is a transcription factor responsible for regulating stress response genes as well as facilitating different anti-proliferative processes (Vogelstein *et al.*, 2000). As a matter of fact, a number of p53 tumor suppressor functions are regulated by miRNAs. In 2007, more than one research group have shown that the members of the miR-34 family are the most commonly p53-induced miRNAs (Bommer *et al.*, 2007; Chang *et al.*, 2007; He *et al.*, 2007; Raver-Shapira *et al.*, 2007). After that several studies demonstrated that the miR-34 family members are crucial mediators of tumor suppression. Members of the miR-34 family have been associated with the regulation of different cancer-related processes, such as epithelial to mesenchymal transition (EMT), proliferation, migration, apoptosis, metastasis, and invasion (Figure 9) (Rokavec *et al.*, 2014). Microarray analyses revealed that after the ectopic introduction of various members of the *miR-34* family into different cell lines hundreds of *miR-34* targets were downregulated. It was revealed that mRNAs that function in cell-cycle control as well as the DNA damage response were among the majority of transcripts found to be downregulated by the *miR-34* family. In addition, these downregulated mRNAs revealed an enrichment of *miR-34* seed-matching sequences in their 3'-UTR regions (Hermeking, 2010).

MiR-34a is a highly conserved miRNA, which is recently identified as a significant tumor suppressor in a number of malignancies through its suppression of multiple targets (Li *et al.*, 2014). *MiR-34a* expression can mainly be regulated through epigenetic modification, genomic loss, and transcriptional regulation (Figure 10). *MiR-34a* is encoded on the distal region of chromosome 1p, where it has been reported that genomic loss of this particular region is found in different malignancies; thus, the loss of the *miR-34a* gene that acts as a tumor suppressor is logical. Although the mechanism through which *miR-34a* is dysregulated in human malignancies is not well understood yet, there remains substantial evidence suggesting that epigenetic changes are involved in the process of carcinogenesis (Nagai, Negrini, Carter, Gillum, Rosenberg, 1995; Attiyeh *et al.*, 2005; Zhang *et al.*, 2010).

Transcriptional silencing through the methylation of CpG islands is considered one of the most significant processes through which tumor suppressor genes are inactivated. In addition, inactivation by CpG methylation can result in clonal growth with a selective advantage during tumorigenesis (Li *et al.*, 2014). Silenced expression of *miR-34a* has been reported in a number of malignancies, such as colon, breast, lung, bladder, kidney, pancreatic cancers due to the hypermethylation of CpG islands in the *miR-34a* gene promoter region. Additionally, upon treatment with DNA methyltransferase inhibitor, 5-aza-2'-deoxycytidine, there was a decline in CpG methylation of *miR-34a*, leading to the reactivation of the *miR-34a* gene. The promoter region far away from the transcription start site was analyzed to reveal that it contains uniformly increased CpG methylation. Thus, silencing the expression of *miR-34a* is believed to be facilitated by CpG methylation of a certain region 100-500 base-pairs upstream of the transcription start of *miR-34a* (Lodygin *et al.*, 2008).

The expression of *miR-34a* is regulated by multiple transcription factors, such as ETS-like protein 1, which was shown to increase the *miR-34a* expression (Antonini *et al.*, 2010). *MiR-34a* is negatively regulated by a member of the p53 family; p63, which is associated with the progression of the cell cycle through the direct repression of *miR-34a* transcription. When p63 is absent, it was observed that the levels of *miR-34a* were elevated in epidermal cell through the direct binding to p53-consensus sites in the regulatory regions of *miR-34a*, thus inhibiting its activity (Siemens *et al.*, 2011).

As the functions of miRNAs in human diseases are being gradually understood, several research groups are currently investigating the role of miRNAs in cancer therapy. Generally, upregulation of miRNAs occurs through the administration of synthetic miRNAs or miRNA-expressing vectors. On the other hand, miRNAs are downregulated through the addition of anti-sense nucleotides. It has been observed that in the majority of tumors, the levels of *miR-34a* are downregulated, which categorizes this miRNA as a tumor suppressor. The significance of *miR-34a* is evident by the numerous factors responsible for its regulation. This complicated network of regulatory mechanisms and transcription factors lead to *miR-34a*'s tissue-specific expression in various types of tumors (Li *et al.*, 2014).

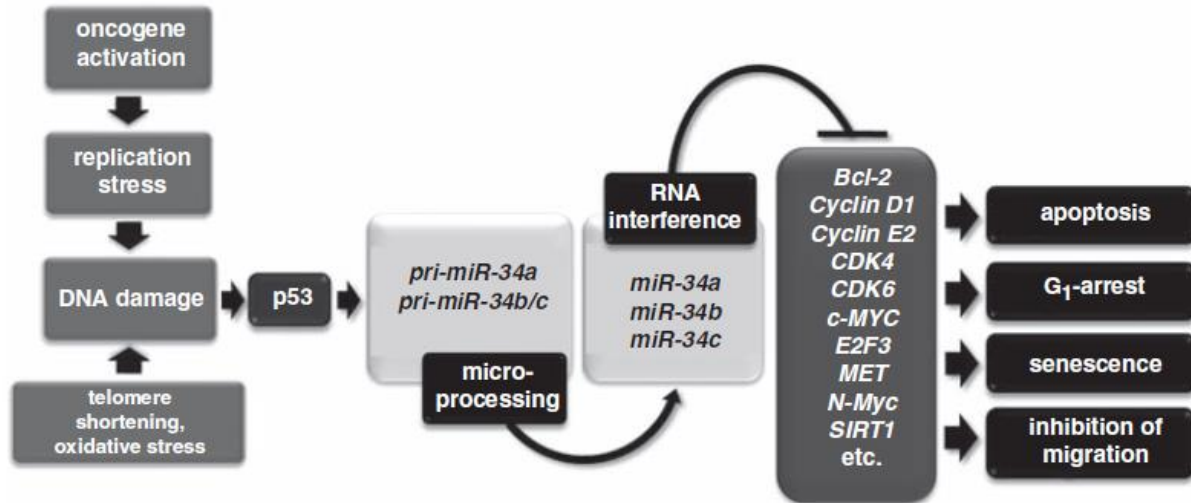

Figure 7. The *miR-34* family as a facilitator of tumor suppression by p53. After double-strand breaks take place, p53 gets activated through ATM-kinases and transactivates other target genes through consensus binding sites. Primary transcripts of the activated *miR-34* genes are then processed by DROSHA and DICER complexes. After that the mature miRNA is incorporated in the RISC complex to either inhibit translation or degrade RNA of specific targets. Adapted with permission from Hermeking, 2010.

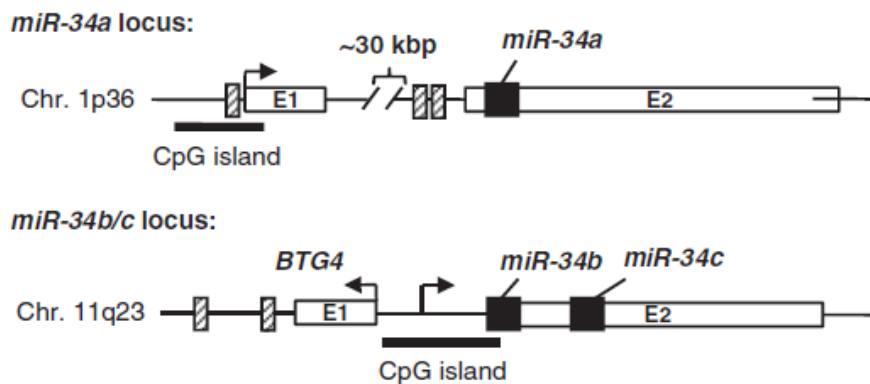

Figure 8. A detailed structure of the genomic loci of human *miR-34a* and *miR-34b/c* genes. The white boxes represent exons, while the miRNA hairpins are represented by the black boxes. The hatched boxes represent the p53-binding sites, whereas the thick black lines indicate the CpG islands location. Adapted with permission from Hermeking, 2010.

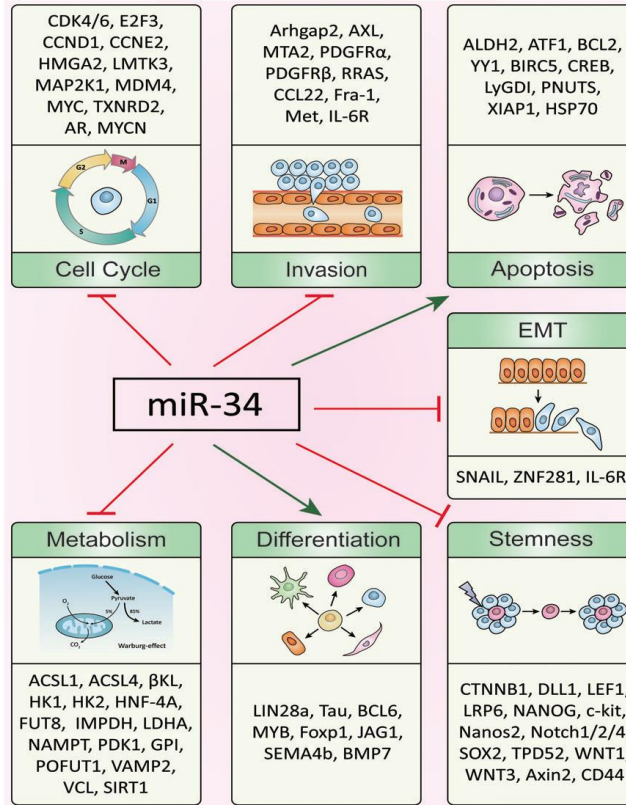

Figure 9. miR-34 regulation in cancer. The regulation of multiple cancer-related processes and pathways by the miR-34 family through the targeting of key factors. Down-regulated proteins due to miR-34 direct targeting are grouped according to their function. The net regulation effect of miR-34 on each pathway is shown by a green arrow (activation) or a red inhibitory sign. Adapted with permission from Rokavec *et al.*, 2014.

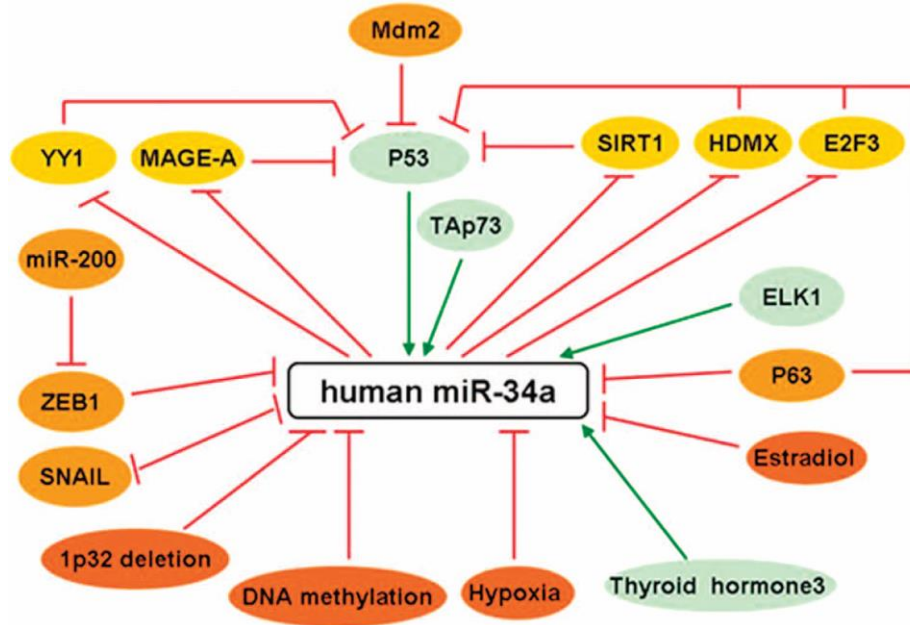

Figure 10. *miR-34a* regulation. A diagram showing the means through which the expression of *miR-34a* is regulated. Inhibition is indicated by the red arrows, while green arrows represent activation. Adapted with permission from Li *et al.*, 2014.

ii. MiR-221:

MiR-221/222 are homologous highly conserved miRNAs in vertebrates encoded in tandem on the X chromosome, in which they act as tumor promoters due to their upregulation in human malignancies (Di Martino *et al.*, 2016). Number of studies have shown the role miR-221/222 play in tumor development either as an oncomiR or oncosuppressor-miRs (Garofalo *et al.*, 2012). MiR-221 was shown to be overexpressed in human cancers, such as glioblastoma, breast cancer, and colorectal cancer. Additionally, it was recently reported that miR-221 stimulates the onset of tumorigenesis and promotes the progression of the tumor, hence shortening the lifespan of mouse models with liver cancer (Li *et al.*, 2011). In 2007, Galardi *et al.* (2007), discovered the cell cycle regulator, p27^{Kip1}, as the target for the miR-221/miR-222 family. They demonstrated that in pancreatic cells, the expression levels of p27^{Kip1} and miR-221/miR-222 are inversely correlated, and showed that overexpression of miR-221/222 significantly affected proliferation and the distribution of the cell cycle phase. These findings were then confirmed in thyroid papillary carcinomas, breast cancer, glioblastomas, lung cancer, and hepatocellular carcinoma.

A study by Li *et al.* (2011) revealed that in the 46 HCC samples tested, miR-221 was significantly elevated in the sera of 35 samples compared to the normal controls. Additionally, it was shown that the significant upregulation of miR-221 was directly correlated with the size of the tumor, tumor stage, and cirrhosis. Also, it was observed that the expression of miR-221 increases as the TNM (Classification of Malignant Tumors) stage progresses (Figure 11) (Li *et al.*, 2011). However, no correlation has been established between the expression of miR-221 and other clinical factors, such as gender, age, HBV infection, and alcohol abuse. It was concluded that, the more advanced the tumor, the more up-regulated miR-221 expression is, and hence the expression of miR-221 could directly affect the patients' prognosis. As shown in Figure 12, the overall survival rate of HCC patients with high miR-221 expression is significantly lower compared to patients with low miR-221 expression (Li *et al.*, 2011).

Another study by Pineau *et al.* demonstrated that the dysregulation of miR-221 is associated with the progression of liver tumorigenesis, in which they function through the targeting of CDK inhibitors p27 and p57 at the protein level. It was concluded that the expression profiles of certain miRNAs change during the progression of liver tumorigenesis, in which some act as real oncomiRs, such as miR-221 (Pineau *et al.*, 2010). Additionally, Fornari *et al.* (2008) showed that CDKN1C/p57 is a direct target of miR-221 in the liver, proving further the oncogenic function of miR-221 in hepatocarcinogenesis. As expected, the transfection of miR-221 in Hep3B cells resulted in 1.8-fold decrease of CDKN1C/p57, while the transfection of SNU449 cells with anti-miR-221 there was a 1.3-fold increase in the protein levels of CDKN1C/p57 when compared to negative control miRNA inhibitors (Garofalo *et al.*, 2012).

In another study, patients with chronic HCV infection had elevated levels of miR-122a expression as well as AST and ALT, which were positively correlated with the upregulation of miR-221. The elevated levels of miR-221 may reflect the liver damage caused during the course of the chronic HCV infection; and thus, the levels of circulating miR-221 can be an indicator of the disease activity (Ding *et al.*, 2015). This study showed the significant upregulation of miR-221 in the serum of chronic HCV patients, which is suggested to be through the association of miR-221 with the NF- κ B cascade. Several studies have demonstrated the activation of NF- κ B-dependent inflammatory pathways in chronic viral hepatitis, cirrhosis, and HCC (Figure 13). NF- κ B has a binding site at the promoter region of miR-221, in which the upregulation of miR-221

could be completely blocked by NF- κ B inhibitor (PDTC), suggesting that the upregulation of miR-221 during HCV infection occurs in a NF- κ B dependent manner (Ding *et al.*, 2015).

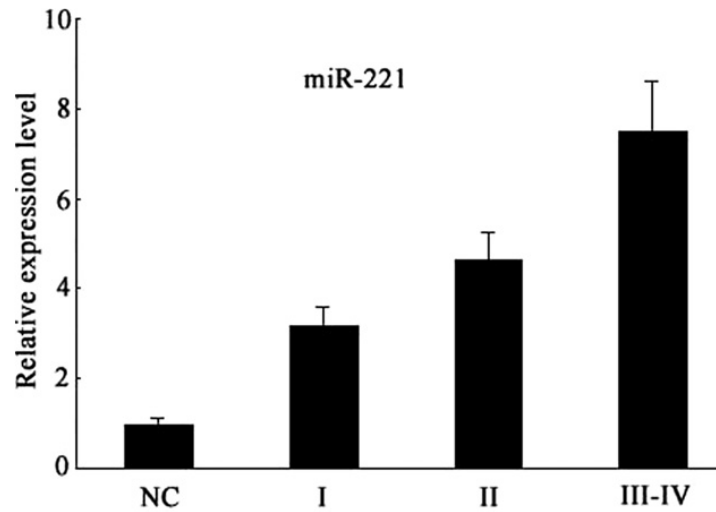

Figure 11. MiR-221 Expression. MiR-221 expression pattern in normal controls compared to different clinical stages of HCC serum samples. Significant differences were evident between the different groups ($p < 0.05$). Adapted with permission from Li *et al.*, 2011.

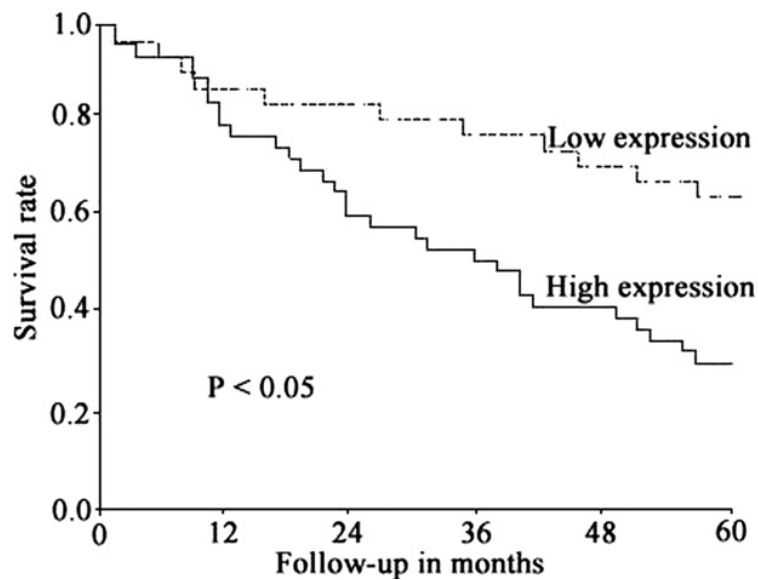

Figure 12. Kaplan-Meier survival curves of HCC patients. The 5-year overall survival rate of HCC patients with high serum expression of miR-221 was considerably lower compared to HCC patients with low expression of miR-221. Adapted with permission from Li *et al.*, 2011.

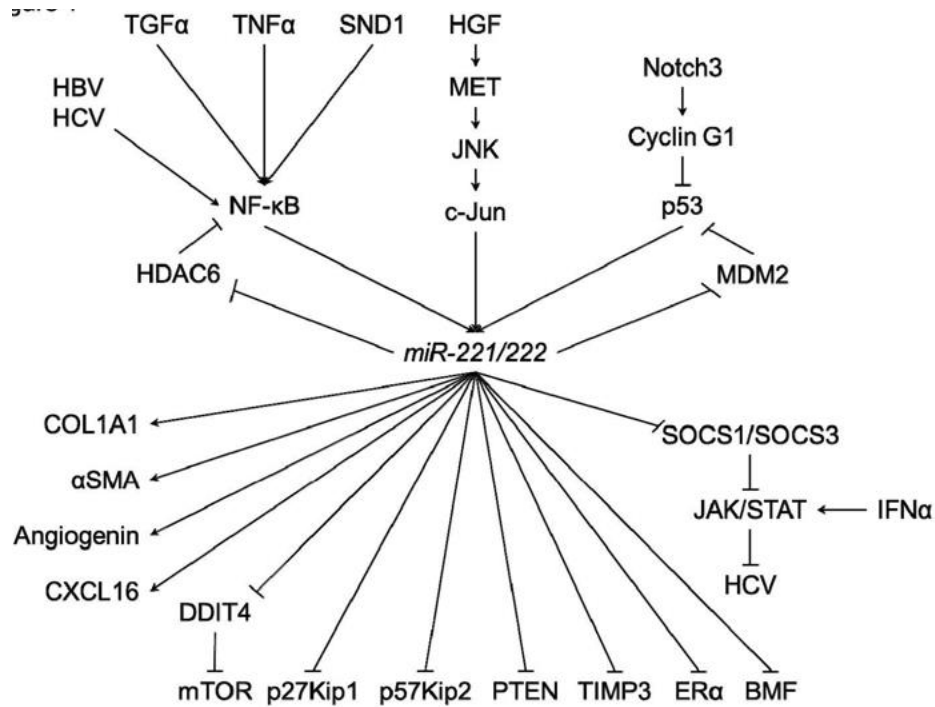

Figure 13. MiR-221 Regulation. The regulatory mechanisms of the *miR-221/222* family in hepatocarcinogenesis. Adapted from Matsuzaki & Suzuki, 2015, open access article, no permission.

iii. MiR-199a:

MiR-199a is located on chromosome 19 in the dynamin-2 gene within intron 14. MiR-199a is one of the most highly expressed miRNAs in the normal liver (Song *et al.*, 2014). Several studies have shown that the expression of miR-199a is down-regulated in several types of cancer, including HCC. MiR-199a was shown to be down-regulated in prostate, ovarian, colon, renal, bladder cancers, and oral squamous cell carcinoma, while it was up-regulated in gastric cancer, bronchial squamous cell carcinoma, and cervical carcinoma (Song *et al.*, 2014). In a study by Li *et al.* (2016), systematic analysis revealed that miR-199a is significantly decreased in HCC cases, and hence it functions as a tumor suppressor through the inhibition of the oncogenesis thus preventing tumor development. As a tumor suppressor, miR-199a was shown to negatively regulate cMet, which is an important oncogene that plays a role in invasion and metastasis of HCC. Therefore, in HCC cell lines it was shown that overexpression of miR-199a decreases invasion and proliferation. Moreover, in gastric cancer, miR-199a is known to regulate the tumor suppressor mitogen-activated protein kinase kinase kinase 11 (Li *et al.*, 2016). In another study by Song *et al.* (2014), qRT-PCR results demonstrated that miR-199a is

involved in the regulation of human hepato-carcinogenesis, in which its expression levels were decreased by 82.5% in HCC tissues compared adjacent non-neoplastic liver tissue. Additionally, the cell line expression displayed a similar pattern to that found in tissues. Further analysis also revealed that the low expression of miR199a correlated with worse HCC patients' prognosis, in which clinical features analysis of 40 HCC patients showed decreased expression of miR-199a in association with the TNM stage of patients and tumor metastasis. After that, survival analysis revealed that the down-regulation of miR-199a was significantly correlated with poor prognosis for HCC patients (Song *et al.*, 2014).

The members of the miR-199 family include, miR-199a-5p, miR-199a-3p, and miR-199b, which are all known to be down-regulated in HCV-induced HCC cases when compared to healthy controls and cases with post-hepatitis cirrhosis and liver failure (El-Abd *et al.*, 2015). The strong association of miR-199a/b with HCC, regardless of the etiology, is very evident in all expression analysis profiles especially that it the third most highly expressed miRNA in liver tissue (Diaz *et al.*, 2013). The expression of miR-199a/b has always been down-regulated in HCC patients with different etiologies, such as HBV, HCV, and high alcohol consumption. As previously mentioned, the strong correlation between HCC and miR-199a/b has been demonstrated through the poor rate of survival, short time to tumor recurrence, growth inhibition of HCC *in vivo* and *in vitro* following administration of miR-199a/b, and the down-regulation of tumor-promoting pathways such as mTOR, c-MET, and PAK4/Raf/MERK/ERK (Diaz *et al.*, 2013).

iv. MiR-16:

In 2002, Calin *et al.* demonstrated that miR-16 is located within a small region of the 13q14 chromosome, which was found to be deleted in more than 65% of chronic lymphocytic leukemia (CLL) cases. Their study showed that allelic loss in this chromosomal region is associated with the down-regulation of miR-15 and miR-16 suggesting that these genes are inactivation targets by allelic loss found in CLL, which was one of the first pieces of evidence to suggest the importance of miRNA genes in tumorigenesis. The mapping of the *miR-15a* and *miR-16-1* genes in a region usually altered in cancer served as evidence that these two miRNAs could be the 13q14.3 target genes. Number of studies of CLL as well as solid tumors have

demonstrated the deletion or down-regulation of *miR-15a* and *miR-16-1* in malignant cells, implicating that these two miRNAs could be ‘hot spots’ in tumor transformation (Calin & Croce, 2006). Expression analysis of *miR-15a* and *miR-16-1* in prostate cancer showed consistent down-regulation of these two genes in approximately 80% of tumor tissue samples compared to that of normal tissues. Additionally, no association has been reported between the loss of *RB*, which is located in the same area, and the down-regulation of *miR-15a* and *miR-16-1*, thus suggesting that *miR-15a* and *miR-16-1* down-regulation or loss is independent of the absence of the RB encoding gene (Figure 14). Additionally, lower expression of *miR-15a* and *miR-16-1* was shown in pituitary adenomas compared to normal pituitary tissues. Collectively, these data suggested that *miR-15a* and *miR-16-1* function as tumor suppressors where their inactivation by allelic loss contributes to carcinogenesis (Bottoni *et al.*, 2005).

It was found that the sequences of *miR-15a* and *miR-16-1* and the *BCL2* mRNA have a complementary homology, hence suggesting that the oncoprotein Bcl2 might be a post-transcriptional repression target by the tumor suppressors, *miR-15a* and *miR-16-1* (Cimmino *et al.*, 2005). Bcl2 has a critical role in the eukaryotic cell genetic program, in which it favors survival through cell death inhibition. Therefore, the up-regulation of Bcl2 has been shown in several types of human tumors, such as carcinomas, leukemias, and lymphomas (Figure 14) (Sanchez-Beato, Sanchez-Aguilera, & Piris, 2003). In a study by Qu *et al.* (2011), where they investigated the expression levels of liver-specific miRNAs in the sera of HCC patients and chronic liver disease (CLD) patients, the data revealed that the serum levels of miR-16 were noticeably lower in HCC patients compared to CLD and normal individuals. As a matter of fact, miR-16 was identified in 76 out of 105 HCC patients, which as a single marker had the highest sensitivity of all other miRNAs investigated. Additionally, combining miR-16 with other conventional HCC biomarkers such as, AFP, AFP-L3, and DCP resulted in great diagnostic accuracy, with a specificity of 78.5% and sensitivity of 92.4% (Qu *et al.*, 2011). Additionally, Qu *et al.*, investigated the miRNA expression in the sera of patients with tumor size ≤ 3 cm, where miR-16 was identified in 34 out of the 43 patients with small tumor size, which was a more than the number identified with the conventional serum HCC markers (Qu *et al.*, 2011). On the other hand, in another study by Tan *et al.*, although miR-16 was significantly down-regulated in HCC

patients compared to the controls, yet it did not meet the candidate miRNA selection criteria set by the research team at the microarray level (Tan *et al.*, 2014).

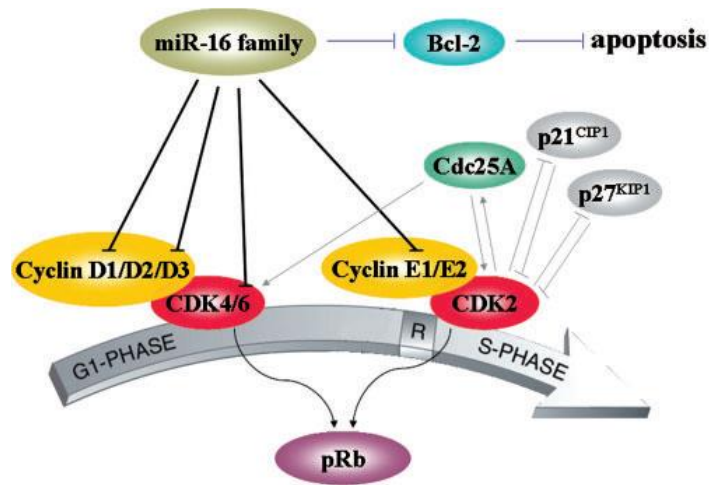

Figure 14. MiR-16 Regulation. Through the regulation of Cdk4/6-cyclin D complexes and Cdk2-cyclin E complexes, the miR-16 family facilitates the G1/S transition. The transition of G1/S is mainly regulated by 2 complexes, D-type cyclins with CDK4/CDK6 and E-type Cyclins with CDK2. The two complexes are responsible for the phosphorylation and inhibition of Rb and E2F binding, resulting in the activation of E2F-mediated transcription and transitioning the cells from the G1 to the S phase. The inactivation of Cdk2/4/6 as well as the expression levels of Cyclin E1, Cyclin D1, Cyclin D3, and CDK6 are controlled by the miR-16 family, and hence preventing the Rb proteins phosphorylation. Additionally, miR-16 is responsible for inducing apoptosis through the downregulation of Bcl-2, an anti-apoptotic protein. Adapted from Liu *et al.*, 2008, open access article, no permission.

v. MiR-122a:

MiR-122a is undetectable in the majority of tissues, while it accounts for approximately 70% of the total liver microRNA population. MiR-122a has critical functions in the regulation of hepatocyte development, lipid metabolism, stress response, and differentiation (Nakao, Miyaaki, & Ichikawa, 2014). The expression of miR-122a is determined by liver-enriched transcription factors (LETFs), that also include hepatocyte nuclear factor (HNF) 4a and 6, that also regulates the dosage of miR-122a *in vivo* during liver development (Xu *et al.*, 2010; Laudadio *et al.*, 2012; Deng *et al.*, 2014). As a matter of fact, during liver development, the increased expression of miR-122a and LETFs is believed to maintain the balance between cellular differentiation and proliferation in cholangiocyte and hepatocyte lineages. This sequential regulation of the expression of miR-122a is crucial since miR-122a plays a role in hepatobiliary segregation while maintaining a hepato-specific phenotype. In mouse models for liver development, miR-122a is responsible for the terminal liver differentiation through gradually repressing the transcription

factor cut-like homeobox 1 (CULT1) (Figure 10) (Xu *et al.*, 2010). The function of miR-122a in liver development and differentiation was studied further by demonstrating that miR-122a antisense-mediated inhibition delayed the development of the liver in zebrafish models, and resulted in the expression of suppressed genes in the liver of adult mouse models. Additionally, this was proven further by that fact that in primary HCC with poor prognosis, miR-122a repression was associated with hepatic phenotype suppression (Krützfeldt *et al.*, 2005; Coulouarn, Factor, Andersen, Durkin, & Thorgeirsson, 2009).

In the case of liver disease, the use of germline knock-out (KO) mice and liver-specific KO mice has been extremely helpful in demonstrating the key role miR-122a plays in the development and progression of liver disease (Bandiera *et al.*, 2015). It was demonstrated that the genetic loss of miR-122a not only severely impacts lipid metabolism, but initiates inflammation and microsteatosis that led to the development of steatohepatitis and fibrosis as the mice got older. Additionally, carbon tetrachloride-induced mouse model of liver fibrosis showed a low expression of miR-122a (Hsu *et al.*, 2012; Tsai *et al.*, 2012). As a matter of fact, restoring the levels of miR-122a in miR-122a KO mice caused liver inflammation to be partially reversed, through the repression of miR-122a targets, the chemokine Ccl2 responsible for the intrahepatic recruitment of CD11b^{hi}Gr1⁺ inflammatory cells, and the pro-fibrogenic Krüppel-like factor 6 (KLF6) that is up-regulated in the miR-122a KO mouse liver. These findings demonstrated clearly the anti-fibrotic and anti-inflammatory functions of miR-122a in the liver (Hsu *et al.*, 2012; Tsai *et al.*, 2012).

MiR-122a stimulates the replication of HCV through the direct binding to the HCV RNA on the HCV 5'UTR, while it inhibits HBV replication through the p53-mediated inhibition of HBV transcription. MiR-122a functions as a tumor suppressor as it inhibits the development of HCC through binding to target genes responsible for HCC cellular proliferation, differentiation, migration, angiogenesis, and apoptosis (Nakao, Miyaaki, & Ichikawa, 2014). It has been reported in several studies that miR-122a is down-regulated in HCC tissue in comparison to adjacent normal tissue, in which loss of miR-122a expression has been associated with HCC metastasis and poor prognosis. Coulouarn *et al.* (2009) reported that in HCC tissue, loss of expression was associated with low apoptotic index and high proliferation. MiR-122a down-regulation has also been observed in several HCC human cell lines, even though the miR-122a expression levels vary with more than 1000-fold differences among various cell lines (Coulouarn *et al.*, 2009).

MiR-122a serum expression levels have been studied in patients with HCC as well as other chronic liver diseases (Nakao, Miyaaki, & Ichikawa, 2014). The miR-122a serum levels were not significantly different between HCC patients compared to patients without HCC; however, they correlated positively with liver transaminases and were negatively correlated with the Model for End-Stage Liver Disease (MELD) score, which indicates that circulating serum miR-122a is a reliable biomarker for liver injury but not necessarily for HCC (Nakao, Miyaaki, & Ichikawa, 2014).

Several research groups have identified different target genes of miR-122a that play a role in hepatocarcinogenesis and epithelial mesenchymal transition (EMT). For example, the expression of cyclin G1 is directly down-regulated by miR-122a, resulting in an inverse relationship between the expression of cyclin G1 and miR-122a in HCC tissue (Gramantieri *et al.*, 2007). Deregulation of cyclin G1 has been shown to be associated with genomic instability, where the over-expression of cyclin G1 has been demonstrated in leiomyoma, breast, and colorectal cancer. Additionally, laboratory evidence from cancer cell lines and tumor xenografts demonstrated that loss of cyclin G1 leads to tumor growth inhibition by decreasing proliferation and inducing apoptosis. For example, in experimental hepatocarcinogenesis, loss of cyclin G1 is correlated with a noticeably low tumor incidence following a carcinogenic incident, in which cyclin G1-null hepatocytes enter the S phase at a slower rate (Gramantieri *et al.*, 2007). MiR-122a is also known to up-regulate the p53 expression and its transcriptional functions through the negative regulation of cyclin G1 of p53 protein's stability that acts on the B' subunit of phosphatase 2A (Nakao, Miyaaki, & Ichikawa, 2014).

Finally, the down-regulation of miR-122a was shown to be associated with poor prognosis and liver cancer metastasis. Additionally, number of miR-122a targets have been shown to be associated with tumorigenesis, such as cyclin G1, ADAM10, IGF1R, SRF, and Wnt1, in which they contribute to hepatocarcinogenesis, angiogenesis, and epithelial-mesenchymal transition (Bandiera *et al.*, 2015). All these data compiled together provide the evidence that miR-122a functions as a tumor suppressor in the liver. Furthermore, by experimenting on a mouse model that developed a tumor without inflammation, it has been shown that miR-122a functions as an anti-tumor molecule that acts independently of its other functions of liver disease prevention and inflammation. Therefore, besides miR-122a being a specific and sensitive diagnostic biomarker, it

also has the potential of being used as a therapeutic tool for the treatment of HCC (Bandiera *et al.*, 2015).

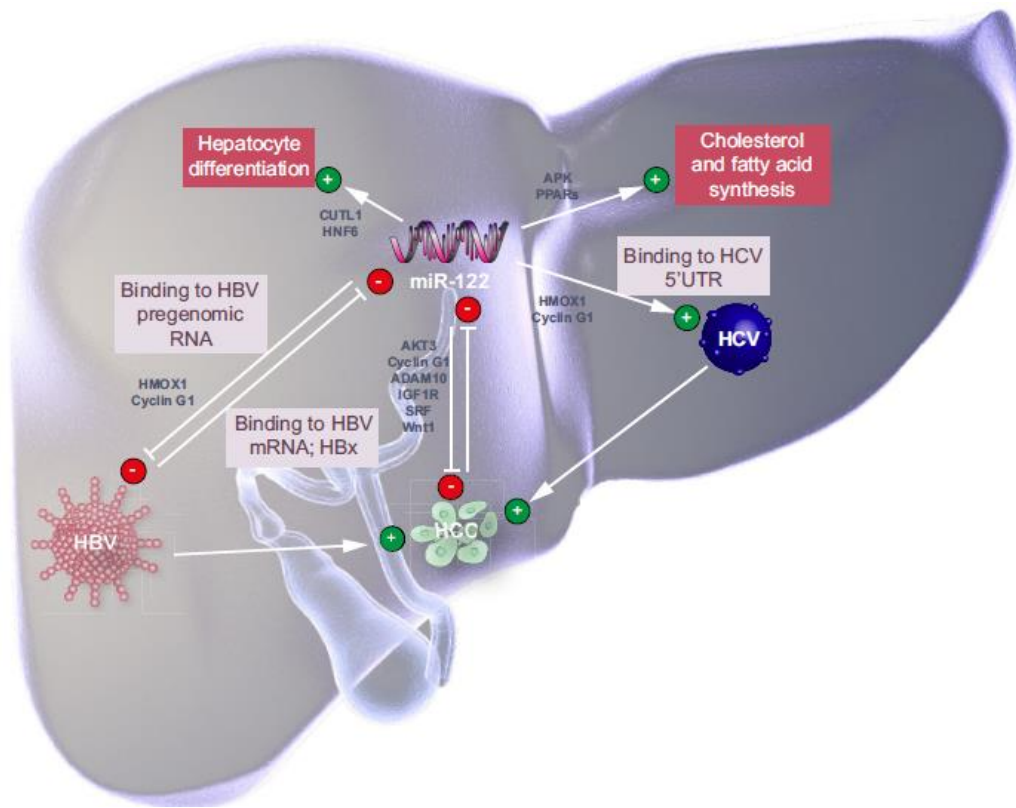

Fig. 15. MiR-122 is a crucial regulator of liver development and disease. An illustration showing the various roles of miR-122 in hepatogenesis and metabolism (red boxes) and its involvement in viral hepatitis and liver disease. Also shown is the effect of miR-122 on the activation (+) or inhibition (-) of specific processes. Viral origins miR-122 targets are shown in grey boxes, while the host miR-122 targets are illustrated outside boxes. Adapted with permission from Bandiera *et al.*, 2015.

vi. MiR-125a:

MiR-125a is located on chromosome 19q13, that has been shown to be frequently deleted in several types of human cancers. In a study by Scott *et al.* (2007) it was shown that over-expression of miR-125a decreased the anchorage-dependent growth, invasion, and migration of breast cancer cells through the down-regulation of ERBB2 and ERBB3 in the ERBB2-dependent SKBR3 cell line. Additionally, studies showed that during treatment with trastuzumab, miR-125a plays a role in inhibiting the proliferation of human gastric cancer cells (Bi *et al.*, 2012). MiR-125a was also shown to be down-regulated in non-small cell lung cancer, in which it had reverse impact on the invasion and migration of the lung tumor cells. On the other hand, in the

case of ovarian cancer, miR-125a over-expression promotes the conversion of very invasive tumor cells from a mesenchymal origin to an epithelial morphology, indicating that miR-125a negatively regulates EMT (Figure 16) (Jiang *et al.*, 2010).

In HCC, miR-125a was shown to be frequently down-regulated when compared to normal adjacent liver tissue, and it is associated with the tumor progression in HCC patients (Bi *et al.*, 2012). In HCC cell line, miR-125a ectopic expression could also repress proliferation and metastasis *in vivo* and *in vitro*. MiR-125a can arrest the translation of the mRNA of the tumor suppressor gene, p53, which hinders the expression of HBV surface antigen. Using the miRanda and Pic Tar algorithms for analyses showed number of cancer-associated genes, such as ERBB2, EDN1, MMP11, ERBB3, MMP14, VEGF-A, and BCL-2L as potential miR-125a target genes. In fact, the over-expression of miR-125a did not suppress the ERBB2 or ERBB3 expression, which are key players in inhibiting breast cancer proliferation and metastasis. In a study by Bi *et al.*, it was found that the expression of MMP11 and VEGF-A is inversely correlated with miR-125a in HCC tissues. According to these findings, Bi *et al.* speculated that miR-125a could play a role in the inhibition of HCC proliferation and metastasis through the partial down-regulation of MMP11 and VEGF-A (Bi *et al.*, 2012).

Zheng *et al.* (2015) reported noticeable increase in the expression of miR-125a-5p in different fibrotic stages, between F1 and F6, which demonstrated that up-regulation in serum miR-125a-5p is associated with the progression of liver disease. Using multivariate logistic regression analysis, liver miR-125a-5p was identified as an independent indicator of the progression of liver disease. Additionally, Zheng *et al.* (2015) showed that the serum levels of miR-125a-5p were significantly down-regulated in the HCC patient group when compared to fibrotic patients and healthy controls. Moreover, serum miR-125a-5p was up-regulated in patients with HBsAg (hepatitis B surface antigen) (+) HCC, which highlights the correlation between the expression levels of serum miR-125a-5p and hepatitis virus infection. Zheng *et al.* (2015) also reported the correlation between the low expression levels of serum miR-125a-5p and poor patient prognosis, which indicates that serum miR-125a-5p could be a good prognostic marker for HCC. They also found that changes in serum miR-125a-5p expression levels were similar to the expression patterns in liver tissue, suggesting that miR-125a-5p in the serum could

be released from liver tissue since the serum miR-125a-5p expression was higher in liver fibrotic patients and lower in HCC patients.

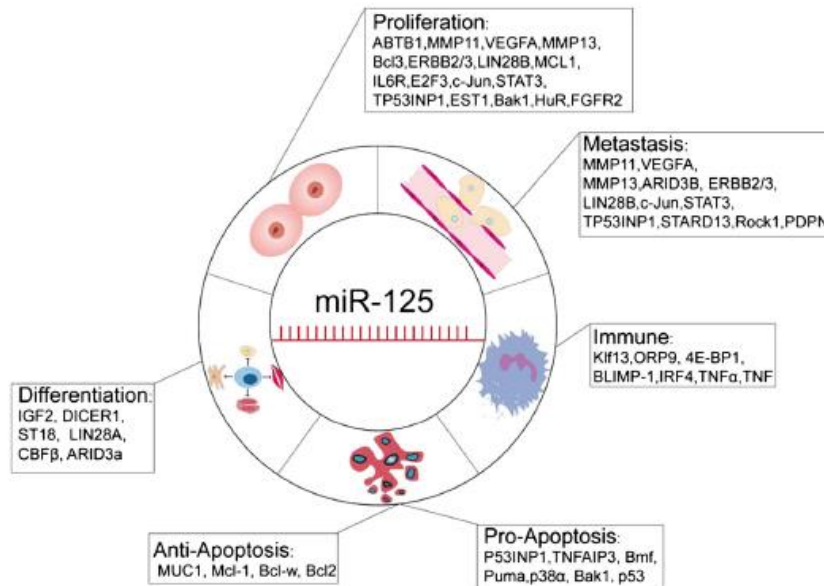

Figure 16. MiR-125 Targets. A schematic representation of the involvement of miR-125 in the pathogenesis of different diseases. MiR-125 can function either as a cancer repressor or promoter. Adapted from Sun, Lin, & Chen, 2013, open access article, no permission.

vii. MiR 139:

MiR-139 is located on chromosome 11q13.4 within the second intron of the phosphodiesterase 2A (PDE2A) gene. MiR-139-5p is the mature miRNA resulting from a miR-130 precursor (Qiu *et al.*, 2015). Decreased miR-139 expression has been shown before in several digestive malignant tumors, such as gastric, colorectal, parathyroid cancers and adrenocortical and squamous cell carcinomas (Li *et al.*, 2014). Wong *et al.* was the first to report that down-regulation of miR-139 in HCC may play a role in suppressing metastasis and cancer cells progression through the down-regulation of Rho-kinase 2, a promoting gene for invasion and metastasis. Additionally, they demonstrated that the down-regulation of miR-139 was significantly correlated with the invasiveness of HCC, in which miR-139 re-expression in HCC impacted cell migration and invasion *in vitro* and *in vivo* (Wong *et al.*, 2011). On the other hand, miR-139 had no effect on HCC cellular proliferation *in vitro*, and it only slightly reduced tumor growth in orthotopic tumors. All evidence demonstrated that the function of miR-139 is primarily an anti-metastatic miRNA in HCC (Wong *et al.*, 2011). In 2014, Li *et al.* used miRNA

microarray analysis to show that the expression of miR-139 was significantly lower in hepatocellular carcinoma tissues when compared to adjacent peritumoral non-malignant tissues. Additionally, expression analysis revealed that the average miR-139 expression in the HCC group was 0.009, that was significantly lower than that of the chronic HBV group of 3.516.

In another study by Gu *et al.* (2014), they studied miR-139 as a potential HCC miRNA anti-oncogene. Their results revealed that expression levels of miR-139 were significantly lower in HCC tissues compared to normal liver tissue, indicating that miR-139 may play a role in hepatocarcinogenesis. They also showed that over-expression of miR-139 suppressed cellular proliferation and invasion in HCC. Additionally, apoptosis was significantly induced after miR-139 transfection. Therefore, they inferred that miR-139 may work as an anti-cancer gene and has an important function in inhibiting cell growth and invasion in HCC. They then used miRanda algorithm, which identified TCF-4 as a potential tumor suppressor target of miR-139. After running a 3'UTR luciferase assay, it was detected that the luciferase activity has increased after the miR-139 inhibitor and a 3'UTR vector with the TCF-4 miR-139 target sequence was co-transfected. The expression of the TCF-4 protein has significantly increased in Hep3B and HepG2 cells that experienced miR-139 inhibitor transfection, therefore signifying that miR-139 uses TCF-4 as a direct target (Gu, Li, & Wang, 2014). Another study by Qiu *et al.* (2015) showed that the increased expression of miR-139-5p suppressed invasion and migration of Hep3B and SMMC7721 cells, in addition to controlling EMT-related gene expression. Additionally, they found two potential miR-139-5p targets, ZEB1 (zinc finger E-box binding homeobox 1) and ZEB2, in which their interaction with miR-139-5p was confirmed through conducting luciferase reporter assays. They concluded that the over-expression of ZEB1 and ZEB2 in SMMC7721 and Hep3B cells resulted in reversing the miR-139-5p inhibitory effects.

viii. MiR-145:

MiR-145 is 22-nt long that a genomic site located in a fragile region of chromosome 5q, which shows a frequent loss of heterozygosity (LOH) associated with hepatocarcinogenesis. The down-regulation of miR-145 has been shown in different types of cancer such as, lung adenocarcinoma, hepatocellular carcinoma, ovarian, colon, and bladder cancers (Wang *et al.*, 2014). Several transcription factors have been identified that control miR-145 expression, in

which it was shown that the silencing of miR-145 is modulated by an epigenetic mechanism. Post transcription, before its maturation the pri-miR-145 passes through processing steps that involve several factors essential at the post-transcriptional level (Cui, Wang, & Chen, 2014). Several studies have shown number of miRNAs regulated by p53, such as miR-107, miR-34a, miR-192/215, and miR-145. Sachdeva *et al.* (2009) reported that p53 could upregulated miR-145 through the direct binding to the p53 response elements-2 (p53RE-2) in the miR-145 promoter (Figure 17). Low levels of miR-145 were shown in laser capture microdissected prostate tissues and 47 cancer cell lines to be associated with p53 mutations (Suh *et al.*, 2011). Shi *et al.* (2012) demonstrated that in cervical cancer when glucocorticoid-induced human papillomavirus oncoprotein E6 (HPV-E6) is activated, it resulted in the suppression of p53 and miR-145 expression.

It was demonstrated that miR-145 inhibits the proliferation of cancer cells and might function as a tumor suppressor. It was previously shown in miRNA profiling of HCV-induced HCC that miR-145 was down-regulated progressively from cirrhosis through dysplastic nodules to HCC, that progresses further to metastasis. Also, the down-regulation of miR-145 in hepatocellular carcinoma was shown to be correlated with poor prognosis and histological grade (Wang *et al.*, 2014). Therefore, it is postulated that miR-145 plays a role in HCC development with a malignant potential. It has been reported that in HCC cells, miR-145 was associated with several mediators of insulin-like growth factor (IGF) signaling, which is an oncogenic pathway that is usually over-activated in HCC (Wang *et al.*, 2014). Wang *et al.* demonstrated that the down-regulation of miR-145 happened frequently in human HCC from different etiologies. Restoring the expression of miR-145 resulted in inducing cell cycle arrest and inhibiting cell proliferation in HCC cells, suggesting that miR-145 functions as a tumor suppressor.

The down-regulation of miR-145 was shown to be significantly correlated with the TNM stage, tumor size and grade, intrahepatic metastasis, and vascular invasion. miR-145 also impairs the invasion of HCC cell lines and could potentially target a disintegrin and metalloprotease 17 (ADAM17), which suggests miR-145 might be used as a target and novel anti-cancer therapy tool (Yang *et al.*, 2014). According to Yang *et al.* the over-expression miR-145 significantly down-regulates ADAM17 expression, while the suppression of miR-145 increases ADAM17 expression. ADAM17 over-expression has been shown in prostate cancer cell lines, gastric

tumors, leukemia cell lines, and mammary cancer. ADAM17 is also responsible for inducing growth and invasion of HCC and glioma cells (Yang *et al.*, 2014). ADAM17 functions by releasing important cell surface molecules, such as tumor necrosis factor- α , EGFR, and adhesion molecules, which all play crucial roles in carcinogenesis and metastasis. Yang *et al.* showed that invasion of SMMC-7721 was significantly increased through the inhibition of miR-145 using an anti-miR145, suggesting the inhibitory function miR-145 plays in HCC cell invasion. On the other hand, the knockdown of ADAM17 using siRNA could cause partial inhibition of invasion in SMMC-7721 cells through the induction by anti-miR-145. This finding suggested that maintain positive control levels of ADAM17 is a critical component of the tumor-suppressor functionality of miR-145 in HCC (Yang *et al.*, 2014).

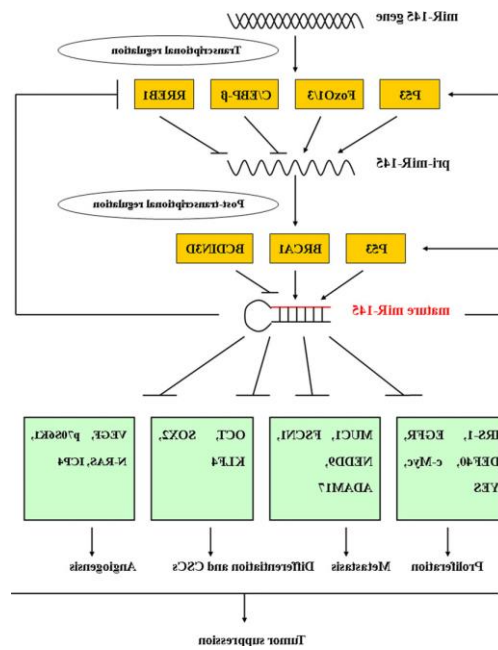

Figure 17: The down-stream targets of miR-145 and its upstream regulation. Transcription of pri-miR-145 is promoted by p53 and FoxO1/3, while its transcription is inhibited by RREB1 and C/EBP- β . MiR-145 processing is regulated at the post-transcriptional level by p53, BRCA1, BCDIN3D and DDX6. IRS-1, EGFR, c-Myc, MUC1, FSCN1, OCT4 and SOX2 are the downstream target genes of miR-145. MiR-145 controls various cellular processes, such as apoptosis, differentiation, proliferation, angiogenesis, and invasion, through the modulation of several oncogenes. Adapted from Cui, Wang, & Chen, 2014, open access article, no permission.

IV. AIM OF THE STUDY

HCC is the third cancer-related cause of death globally, due to several risk factors, of which HCV is a major one. The increasing incidence of mortality among HCC patients is attributed to delayed diagnosis, recurrence, and metastasis. The current diagnostic tools used to detect HCC, such as imaging techniques and serological tumor markers, are not accurate enough to detect HCC at early stages. Therefore, accurate, non-invasive, sensitive, and specific diagnostic tools are needed to detect HCC at early stages of carcinogenesis. Therefore, the aims of this study were to:

1. Investigate the expression profiles of 8 specific miRNAs: miR-16, miR-34a, miR-122a, miR-125a, miR-139, miR-145, miR-199a, and miR-221 in the sera of Egyptian patients with HCV-induced HCC.
2. Evaluate the potential of using these miRNAs as promising non-invasive biomarkers to differentiate between normal, fibrotic, cirrhotic, and HCC patients.
3. Pick the miRNAs with the highest sensitivity and specificity as potential biomarkers to diagnose HCV-induced HCC at early stages of the disease.

V. MATERIALS AND METHODS

A. Sample Collection

Hundreds of patients are regularly admitted at the Hepato-Gastroenterology Department, Theodor Bilharz Research Institute (TBRI), Giza, Egypt, for evaluation of their HCV-related chronic liver disease, out of which 165 patients were selected to be enrolled in this study based on specific screening criteria. All participants signed informed consents before participating in the study, according to the guidelines of TBRI Institute's Human Research Ethics Committee and in compliance with the guidelines of the 1975 Declaration of Helsinki as reflected by approval of the TBRI and AUC's human research ethics committee.

After acquiring the patients' full medical history, they were subjected to thorough clinical examination and assessed by: (a) laboratory testing; including urine and stool analysis, liver function tests, serological diagnosis of schistosomiasis and viral hepatitis PCR (which were performed routinely for the patients upon admission), (b) ultrasonography, and (c) liver biopsy using ultrasound-guided Menghini needle. All procedures, including liver biopsy, were medically indicated for patient management.

Patients were enrolled in the study if they had:

- Clinical and laboratory evidences of chronic hepatitis C virus
- Circulating anti-HCV (genotype-4) antibodies detected by ELISA
- HCV-RNA viraemia detected by nested RT-PCR
- Histopathological features of chronic hepatitis C in liver biopsy specimens
- Focal hepatic lesion indicative of malignancy detected by abdominal ultrasonography and was confirmed to be HCC by histologic assessment

Patients were disqualified from participating in this study if they had:

- Parasitological, serological, histopathological, or ultra-sonographic findings suggestive of other etiologies of chronic liver disease, such as:
 - *Schistosoma* infection
 - Hepatitis B virus infection or dual B and C viral infection
 - Biliary disorders
 - Other malignancies

- HCV-infected patients receiving immunomodulatory interferon- α therapy were excluded as well from the study.

Based on previously published work, patients were divided into three groups. 1) chronic hepatitis C (CHC) virus infection group (n= 42), 2) liver cirrhosis (LC) group (n= 45), and 3) patients with histopathological findings consistent with HCC (n= 38). Age- and sex-matched individuals (n=40) who had undergone laparoscopic cholecystectomy were included in this study as controls. After receiving their written consent, wedge liver biopsies were obtained from these cases as well as from the control subjects to serve as the control specimens for the histopathological studies. All procedures were medically indicated for patient management.

B. Histopathologic Study

Assessment of grade of inflammation and stage of fibrosis was carried out in 5 μ m thick serial sections of formalin-fixed, paraffin-embedded blocks, stained with hematoxylin/eosin and Masson trichrome stains. The stage of hepatic fibrosis was determined according to the Metavir scoring system (F0, F1, F2, F3 & F4) (Lawrie *et al.*, 2008). The Metavir scoring system is used to evaluate the extent of liver inflammation and fibrosis through the histopathological examination of liver tissue of HCV patients. The stage indicates the extent of the fibrosis of the scarring. The fibrosis stages are as follows:

- F0: no fibrosis
- F1: portal fibrosis with no septa
- F2: portal fibrosis with few septa
- F3: several septa with no cirrhosis
- F4: cirrhosis

We collected the F0, F1, F2 & F3 in one group, the chronic hepatitis C (CHC) without cirrhosis and the F4 only in another group, the CHC with cirrhosis (LC) group.

C. Urine Analysis

Mid-afternoon urine samples were collected and centrifuged for 5 minutes at 670x g. After centrifugation, drops of the sediment were added onto microscopic slides and examined by light microscopy (El-Shafei, 1962).

D. Stool Analysis

Stool analysis was done at TBRI using the merthiolate-iodine-formaldehyde (MIF) method for detection of helminthes eggs and protozoal cysts in patients' stool samples (Blagg *et al.*, 1955). Briefly, 4 ml of stock solution A (merthiolate 0.1%, formaldehyde-glycerin solution 36-40%) were mixed with 1 ml of stock solution B (iodine 5%, iodied solution 10%) and added to a half gram of stool. Mixed samples were filtered through stainless steel sieves and 7 ml of cold ether were added. After thorough mixing, test tubes were allowed to stand for 2 minutes and centrifuged for 5 minutes at 4200X g. Following centrifugation, drops of the sediments were added onto microscopic slides and examined by light microscopy.

E. Collection of Sera

Blood samples were collected under complete aseptic conditions by clean venipuncture using sterile disposable syringes. About 5 ml of blood were withdrawn from each patient as well as controls. Blood was delivered into clean dry test tubes and allowed to clot at room temperature. 5 ml of whole blood was centrifuged at 1600 rpm for 5 min and the serum was aliquoted into 1.7 ml eppendorf tubes. Serum samples were stored in tightly closed vials at -80°C until used.

F. Liver Function Tests

Alanine aminotransferase (ALT), aspartate aminotransferase (AST), and albumin were measured using the Synchron CX5 (Beckman Coulter, Inc., Fullerton, California, USA). The levels of alpha-fetoprotein (AFP) were measured using the platinum ELISA kit (R&D Systems, Minneapolis, USA). Additionally, the prothrombin time (PT) concentration and des- γ -carboxyprothrombin (DCP) were assessed in the serum samples using commercially available reagents and standard kits.

G. Detection of Circulating Anti-Schistosoma Antibodies

An indirect ELISA based on the method of Voller *et al.* (1976) was applied. Wells of microtiter plate (Immulon II, Dynatech Laboratories, USA) were coated with 100 μ l/well of 10 μ g/ml of *S. mansoni* SEA in 0.06 M carbonate buffer, pH 9.6. After overnight incubation at room temperature, the plate was thoroughly washed with 0.01 M phosphate buffer saline (PBS). Free sites were blocked with 200 ml/well of 1% bovine serum albumin (Sigma Chemicals, St.

Louis, USA), in carbonate buffer and incubated for one hour at 37°C. Following incubation, the plate was thoroughly washed with PBS. Sera were diluted 1:256 in 0.01 M PBS, and 100 µl were delivered/well and the plate was incubated for 30 minutes at 37°C. After incubation, the plate was washed as before and 100 µl of 1:1000 dilution of polyclonal goat anti-human horseradish peroxidase-labeled IgG antibody (Sigma Chemicals, St. Louis, USA) were added/well. The plate was incubated for 30 minutes at 37°C and then washed with PBS. Ortho-phenylenediamine-H₂O₂ substrate solution (100 µl/well) was added and the plate was covered and incubated in the dark for 20 minutes at room temperature. The reaction was stopped by the addition of 50 µl/well of 8 N H₂SO₄. The absorbance of each well was read at 492 nm wavelength using the ELISA microplate reader. The cut-off value to differentiate sero-positive from sero-negative samples was based on the mean value of healthy subjects + 3 SD and was found to be 0.23.

H. Detection of Hepatitis B Surface Antigen (HBsAg)

It was necessary to detect hepatitis B surface antigen in order to rule out contamination with HBV that may affect the miRNA expression profile. Hepatitis B surface antigen was detected in patients' sera using the HBsAg solid phase sandwich ELISA kit (Axiom Diagnostics, Burstadt, Germany). In this assay, wells of a microtiter plate coated with antibody specific to HBsAg were incubated with unknown serum samples and a mixture of anti-HBs Ag horseradish peroxidase-conjugated mouse monoclonal antibodies. After thorough washing to remove excess unbound material, a substrate solution containing 3, 3', 5, 5' tetramethylbenzidine and H₂O₂ was added to the wells. Wells containing HBsAg in serum samples developed purple color which changed to orange when the enzyme/substrate reaction was terminated with 8 N H₂SO₄. The amount of color in the wells was determined photometrically at 450/620 nm wavelength using the ELISA microplate reader and was directly proportional to the amount of bound conjugate and hence the concentration of HBsAg in serum samples.

I. Detection of Anti-HCV (genotype 4) Antibodies

For the purpose of this study, the focus is on HCV genotype 4 since it is the predominant genotype in Egypt. Antibodies to HCV were detected using Version V anti-HCV solid phase indirect ELISA kit (Axiom Diagnostics, Burstadt, Germany). In the anti-HCV antibody test, serum samples were incubated in micro-wells coated with highly purified antigens containing

sequences from the putative core, NS3, NS4 and NS5 regions of HCV. Following thorough washing, the captured anti-HCV antibodies were incubated with goat anti-human peroxidase-labeled IgG antibody. After washing to remove excess unbound conjugate, the bound enzyme was visualized by the addition of a substrate solution containing 3, 3', 5, 5'-tetramethylbenzidine and H₂O₂. A purple color developed in the wells containing anti-HCV positive samples. The enzyme/substrate reaction was terminated with 8 N H₂SO₄ to give orange color. The absorbance of each well was read photometrically at 450 nm wavelength using the ELISA microplate reader. The amount of bound conjugate and hence the color in the wells was directly proportional to the concentration of anti-HCV antibody in serum samples.

J. Detection of HCV (genotype 4)-RNA

Viral RNA was extracted using the QIAamp Viral RNA kit (Qiagen, Valencia, CA) and stored at -80 °C. The serum HCV-RNA level was measured using the One-Step Real Time RT-PCR according to manufacturer's protocol (Carlsbad, CA, USA).

K. RNA Extraction

The miRNeasy extraction kit (Qiagen, Valencia, CA) was used for the extraction of total RNA including miRNAs. For RNA isolation from serum, 200 µl of serum was mixed with 1000 µl of QIAzol lysis reagent according to the manufacturer's protocol. Then 200 µl of chloroform was added to the sample and the mixed solution was centrifuged for 15 minutes at 12,000 x g at 4°C. Following the centrifugation, the upper aqueous phase was transferred to a new Eppendorf tube. Then, upper aqueous phase was pipetted in the RNeasy MinElute spin column and centrifuged at 8000x g for 15 seconds at room temperature. After that, the column was washed twice with RWT and RPE buffers; respectively. The RNeasy MinElute spin column was washed later with 80% ethanol and centrifuged for 2 minutes at 8000x g. The column was centrifuged for 5 minutes at full speed in order for the membrane to dry. Finally, for the RNA precipitation, 15 µl of RNase-free water were added to the column and centrifuged at full speed for 1 minute, and the same step was repeated in order to obtain a final elution volume of 30 µl. DNase treatment (Qiagen, Valencia, CA) was carried out to remove any contaminating DNA. The RNA concentration and quality was determined using the NanoDrop2000 (Thermo Scientific, USA). In general, the concentration obtained was ~300 ng/µl of RNA.

L. MicroRNA Selection Criteria

Eight miRNAs were selected for this study: miR-16, miR-34a, miR-122a, miR-125a, miR-139, miR-145, miR-199a, and miR-221. PubMed search engine was used in order to search for the expression profiles of different miRNAs in HCC. The miRNAs were selected based on the literature previously published that investigated the expression profiles of serum miRNAs in HCC patients as a result of an HCV infection.

M. Evaluating Serum MicroRNA Expression

RT (reverse transcription) and qPCR (quantitative PCR) kits made specifically for accurate miRNA analysis (Applied Biosystems, Foster City, CA, USA) were used to evaluate expression of the 8 chosen miRNAs from serum samples. RT reactions were performed using a TaqMan[®] microRNA Reverse Transcription Kit (Applied Biosystems, Foster City, CA, USA). Each 15 μ L RT reaction included 7 μ L of the RT master mix, 3 μ L of the specific miRNA RT primer, and 5 μ L of the total extracted RNA with a concentration ranging between 1 to 10 ng. All RT reactions were incubated for 30 min at 16°C, 30 min at 42°C, 5 min at 85°C, and then maintained at 4°C.

For qPCR, 1.33 μ L of the RT product were mixed with 10 μ L of TaqMan 2X Universal PCR master mixture (No AmpErase UNG), 1 μ L of the specific TaqMan MicroRNA assay (Table 1), and 7.67 μ L of nuclease-free water to bring the final reaction volume of 20 μ L according to manufacturer protocol. All reactions were run on the StepOnePlus[™] Real-Time PCR System (Applied Biosystems, Foster City, CA, USA) using the following conditions: 95°C for 10 min, followed by 40 cycles at 95°C for 15 sec, and 60°C for 1 min. qPCR was done in duplicates, including no-template controls. Relative expression of miRNA was calculated using the comparative cycle threshold (Ct) ($2^{-\Delta\Delta Ct}$) method (Schmittgen & Livak, 2008), with miR-39 as the endogenous control to normalize the data. The Ct is known as the number of cycles needed for the fluorescent signal to cross the threshold in qPCR. ΔCt was calculated by subtracting the Ct values of miR-39 from the Ct values of the investigated miRNA. On the other hand, $\Delta\Delta Ct$ was then calculated by subtracting mean ΔCt of the control samples from ΔCt of the tested samples. Fold change of the miRNA was calculated by the equation $2^{-\Delta\Delta Ct}$ while using healthy controls as a reference.

Table 1. The Assay identifications (IDs) representing the primers and probes for the 8 microRNAs

| MicroRNA | Assay ID | Target Sequence |
|-----------------|-----------------|--------------------------|
| miR-16 | 000391 | UAGCAGCACGUAAAUAUUGGCG |
| miR-34a | 000426 | UGGCAGUGUCUUAGCUGGUUGU |
| miR-122a | 000445 | UGGAGUGUGACAAUGGUGUUUGU |
| miR-125a | 002198 | UCCCUGAGACCCUUUAACCUGUGA |
| miR-139 | 005364 | UCUACAGUGCACGUGUCUCCAGU |
| miR-145 | 002278 | GUCCAGUUUCCCAGGAAUCCCU |
| miR-199a | 000498 | CCCAGUGUUCAGACUACCUGUUC |
| miR-221 | 000524 | AGCUACAUUGUCUGCUGGGUUUC |

VI. STATISTICAL ANALYSIS

Data were analyzed using Statistical Package for the Social Science (SPSS) version 24 (IBM SPSS, Chicago, IL, USA). Continuous variables are expressed as the mean \pm standard deviation. The analysis of variance (ANOVA) test and the Mann-Whitney (U-test) were used for comparisons of continuous (non-discrete) variables. In the current study, Mann-Whitney was used because the data is considered nonparametric, since the data does not have a normal distribution. ANOVA was used to evaluate expression differences of the chosen miRNAs between patients and controls, while the Mann-Whitney was used for the analysis and comparison of the patient demographic and biochemical data.

Finally, Pearson correlation was used to determine the correlation between the miRNA expression pattern and the patient group. A significant level of $p < 0.05$ was used in this test. To evaluate the diagnostic accuracy of the 8 miRNAs, a receiver operating characteristic (ROC) curve analysis was carried out. The area under the ROC curve (AUC) as well as the 95% confidence interval (CI) were calculated for each miRNA in order to determine the specificities and sensitivities. For the probability (p) value: $p < 0.05$ was considered significant, while $p < 0.001$ was considered highly significant.

VII. RESULTS

A. Demographic, laboratory investigations, and clinical features of the patients

Clinically and biochemically healthy, roughly age and gender matched individuals (n=40) served as a control population for patients with HCV related liver fibrosis, cirrhosis, and primary HCC. Table 2 summarizes the demographic data of both the control subjects and patients, i.e. number, age, and gender. The biochemical parameters, i.e. AST, ALT, albumin, alkaline phosphatase, PT concentration, AFP, and DCP, are as expected, within the reference range for control subjects but significantly elevated in the three patient groups (CHC, LC, and HCC).

Both the demographic and biochemical profiles of the 42 patients with chronic hepatitis C (CHC), 45 patients with liver cirrhosis (LC), 48 patients with HCC, and 40 healthy controls enrolled in this study are illustrated in detail in Table 2. Normal controls were age and sex matched to the patient group. Serum HCV-RNA revealed that all patients were genotype 4a. All enrolled patients had increased ALT, AST, albumin, alkaline phosphatase, PT concentration, AFP, and DCP ($p<0.001$) compared to the control group, in which the AFP and DCP serum levels were significantly increased in the HCC patients compared to the CHC and LC patient groups ($p<0.001$).

Table 2. Demographic and laboratory data of all patients and controls

| Variables | Controls (n=40) | CHC (n=42) | LC (n=45) | HCC (n=38) |
|---------------------------------------|--------------------|--------------------------|--------------------------|--------------------------|
| Age | 47.0±3.5 | 46.4±7.3 | 51.3±4.7 | 48.1±4.1 |
| Gender (M:F) | 3:1 | 3:2 | 7:5 | 6:4 |
| Liver Function Tests (mean±SD) | | | | |
| AST (U/L) | 21.32±1.07 | 46.14±4.77 ^a | 50.84±5.00 ^a | 76.40±7.34 ^b |
| ALT (U/L) | 23.16±1.95 | 44.12±5.50 ^a | 50.84±5.00 ^a | 76.40±7.34 ^b |
| Alkaline phosphatase (U/L) | 189±41 | 331± 36 ^a | 336±48 ^a | 420±33 ^b |
| Albumin (g/dL) | 4.4±0.5 | 3.60±0.74 | 3.8±0.72 | 3.08±0.48 |
| Prothrombin Concentration | 95.6±3.4 | 89.6±4.8 | 41.5±11.1 ^b | 69.4±3.7 ^a |
| Alpha-fetoprotein (IU/mL) | 3.12±0.08 | 8.86±0.11 ^a | 10.11±0.11 ^a | 55.18±0.44 ^b |
| DCP (mAU/ ml) | 30.42±0.70 | 121.49±0.59 ^a | 123.62±0.38 ^a | 456.52±0.66 ^b |

Data are expressed as mean± standard deviations (SD).

Chronic hepatitis C (CHC); liver cirrhosis (LC); hepatocellular carcinoma (HCC).

Normal range for alanine aminotransferase (ALT) and aspartate aminotransferase (AST) is up to 40 IU/L.

Normal range for alkaline phosphatase is up to 250 U/L.

Normal range for albumin is 3.5-5 g/dl.

Normal range for prothrombin concentration is 80-100%.

Normal range for alpha-fetoprotein is 0.1-9.6 IU/mL.

mAU/ml =milli-absorbance unit/ml.

Normal range for des-γ-carboxyprothrombin (DCP) ≤40 mAU/ml.

^ap<0.001 significant increase than control group.

^bp<0.001 significant increase than CHC and LC groups.

B. MicroRNAs expression profiles by qPCR

All miRNAs showed significant increase than control in both the CHC and LC groups ($p<0.01$). Serum levels of miRNA-122a, miRNA-125a, miRNA-139, miRNA-145 and miRNA-199a were significantly lower ($p<0.01$) in HCC than in both CHC and LC groups. MiR-34a showed significant decrease ($p<0.01$) in LC compared to the CHC and HCC groups. On the other hand, miR-16 was significantly decreased ($p<0.01$) in the HCC group compared to the CHC group. MiR-139 was also significantly decreased ($p<0.01$) in the LC group compared to the CHC group (Table 3; Figures 18 & 19).

Table 3. The qPCR expression levels of the 8 serum microRNAs in the studied groups

| miRNAs | Normal | CHC | LC | HCC |
|-------------------|------------|---------------|---------------------------|---------------------------|
| miRNA-16 | 14.26±0.69 | 24.09±0.44** | 23.29±0.46** | 22.35±0.54** ^a |
| miRNA-34a | 27.32±0.19 | 32.69±0.34** | 30.01±0.54** ^b | 32.50±0.94** |
| miRNA-122a | 19.69±0.33 | 545.83±0.79** | 520.94±0.77** | 16.13±0.38 ^{c d} |
| miRNA-125a | 20.57±0.54 | 96.01±4.36** | 100.54±0.81** | 29.96±0.57** ^d |
| miRNA-139 | 29.96±0.57 | 94.63±0.38** | 86.02±0.40** ^e | 30.03±0.43 ^d |
| miRNA-145 | 20.65±0.52 | 85.31±0.53** | 80.74±0.59** | 20.64±0.57 ^d |
| miRNA-199a | 80.23±0.72 | 330.38±0.74** | 311.98±0.72** | 66.16±0.44 ^{c d} |
| miRNA-221 | 22.82±0.38 | 27.17±1.44** | 28.22±0.41** | 28.51±0.46** |

** $p<0.01$ significant increase than control; ^a $p<0.01$ significant decrease than CHC; ^b $p<0.01$ significant decrease than CHC and HCC; ^c $p<0.01$ significant decrease than control; ^d $p<0.01$ significant decrease than CHC and LC; ^e $p<0.01$ significant decrease than CHC

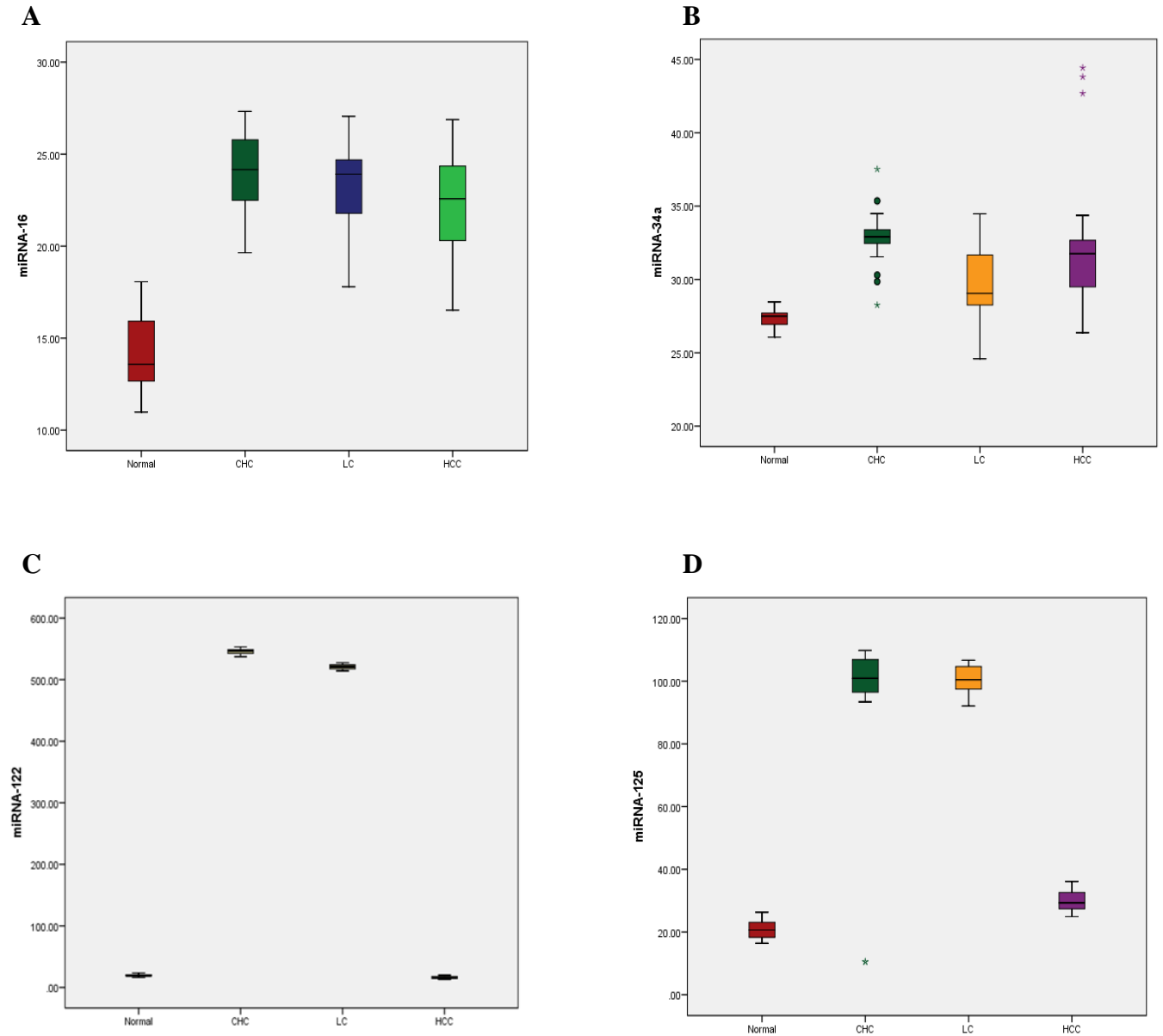

Figure 18. Box Plots- Part 1. Box plot diagrams of the expression of miR-16, miR-34a, miR-122a, and miR-125a, in Hepatitis C virus (HCV)-induced hepatocellular carcinoma (HCC) patients. The box indicates the 25th and 75th percentile of the data and the middle line indicates the median. A line extends from the minimum to the maximum value, excluding outliers that are displayed as separate points.

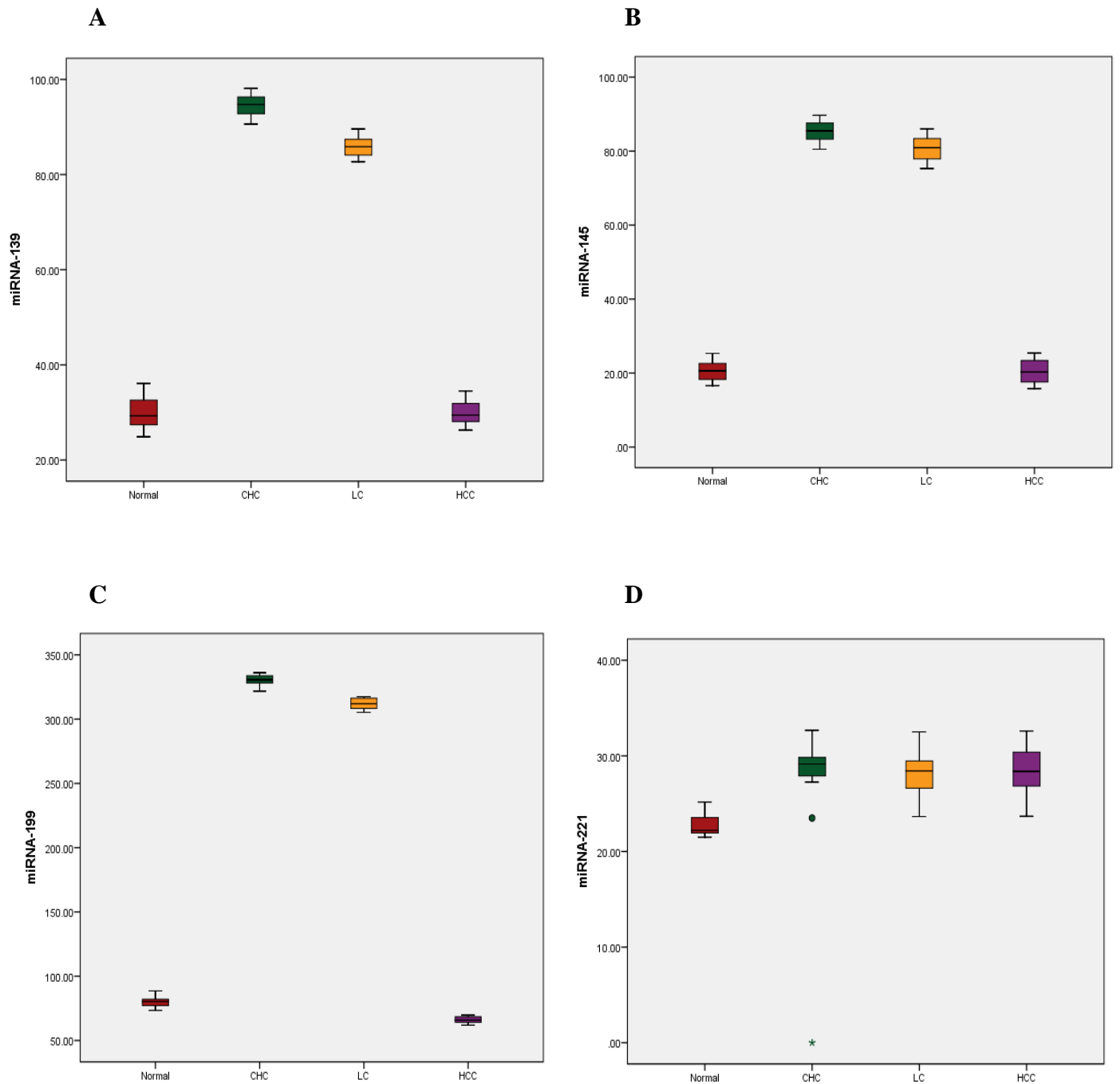

Figure 19. Box Plots- Part 2. Box plot diagrams showing the expression of miR-139, miR-145, miR-199a, and miR-221 in Hepatitis C virus (HCV)-induced hepatocellular carcinoma (HCC) patients. The box indicates the 25th and 75th percentile of the data and the middle line indicates the median. A line extends from the minimum to the maximum value, excluding outliers that are displayed as separate points.

C. Diagnostic performance of circulating MicroRNAs in predicting HCC

To assess the efficacy of the investigated serum miRNAs for predicting HCC, the AUC values (Table 4) were analyzed in order to calculate the sensitivity, specificity, positive predictive value (PPV) and negative predictive value (NPV) for each microRNAs. The sensitivity and specificity of miR-16, miR-34a, miR-122a, miR-125a, miR-139, miR-145, miR-199a, and miR-221 are (80.95%, 70.59%), (96.77%, 81.82%), (95%, 84.21%), (86.67%, 83.33%), (85.71%, 64.29%), (90.91%, 77.78%), (87.10%, 72.73%), and (90.32%, 81.82%); respectively (Table 5). Table 5 displays the sensitivities and specificities of the 8 miRNAs, which were calculated from the ROC curves in order to evaluate the diagnostic potential of the 8 miRNAs. Out of the 8 miRNAs, miR-122a had the highest sensitivity and specificity, indicating that it is a promising biomarker for the early detection of liver cancer. Additionally, miR-125a showed the second highest specificity (83.33), therefore indicating its significance in diagnosis, but not in screening due to the low sensitivity (86.67).

Table 4. Area Under the Curve (AUC), Confidence Interval (CI), and *p*-values for all 8 circulating miRNAs

| MicroRNAs | AUC | CI 95% | <i>p</i> -value |
|-------------------|------------|---------------|-----------------|
| miRNA-16 | 0.716±0.05 | 0.604 - 0.829 | <0.01 |
| miRNA-34a | 0.791±0.04 | 0.695-0.888 | <0.001 |
| miRNA-122a | 0.814±0.04 | 0.721 - 0.908 | <0.001 |
| miRNA-125a | 0.806±0.04 | 0.729-0.884 | <0.001 |
| miRNA-139 | 0.863±0.05 | 0.763-0.962 | <0.001 |
| miRNA-145 | 0.941±0.02 | 0.902-0.980 | <0.001 |
| miRNA-199a | 0.805±0.03 | 0.704-0.906 | <0.001 |
| miRNA-221 | 0.633±0.06 | 0.510-0.757 | <0.05 |

Table 5. The sensitivity and specificity of the 8 microRNAs.

| MicroRNAs | Sensitivity | Specificity | PPV | NPV |
|------------------|--------------------|--------------------|------------|------------|
| miR-16 | 80.95 | 70.59 | 87.18 | 60.00 |
| miR-34a | 96.77 | 81.82 | 93.75 | 90.0 |
| miR-122a | 95.00 | 84.21 | 92.68 | 88.89 |
| miR-125a | 86.67 | 83.33 | 92.86 | 71.43 |
| miR-139 | 85.71 | 64.29 | 82.76 | 69.23 |
| miR-145 | 90.91 | 77.78 | 93.75 | 70.00 |
| miR-199a | 87.10 | 72.73 | 90.0 | 66.67 |
| miR-221 | 90.32 | 81.82 | 93.33 | 75.0 |

PPV: Positive Predictive value NPV: Negative Predictive Value

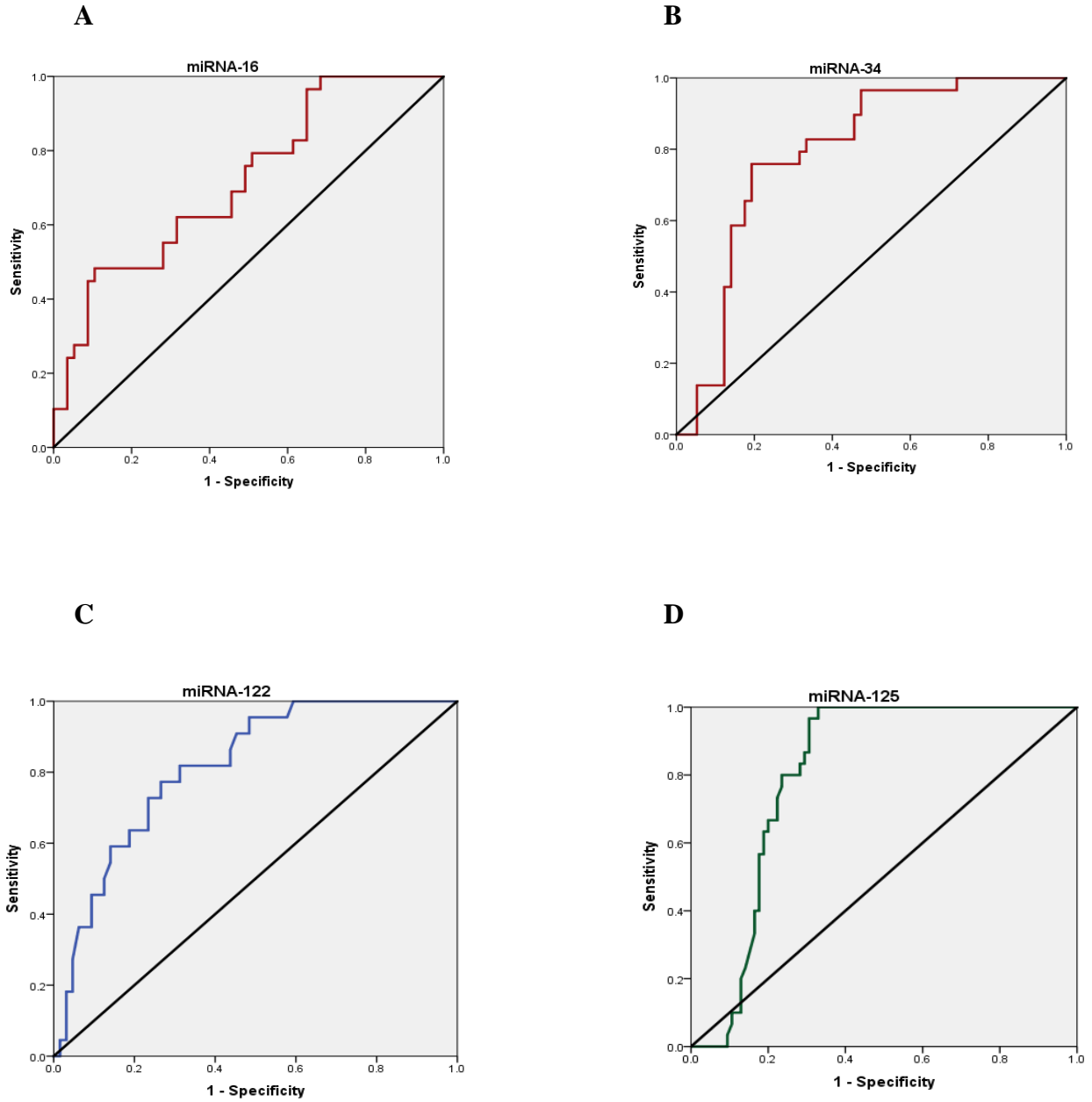

Figure 20. ROC Curves- Part 1. Receiver operator characteristic (ROC) curve analysis displaying the diagnostic power of the miRNAs studied in the hepatocellular carcinoma (HCC) group. Specificities and sensitivities were calculated from the ROC curves, in order to determine which of the miRNAs can be used for diagnosis and which is important for screening.

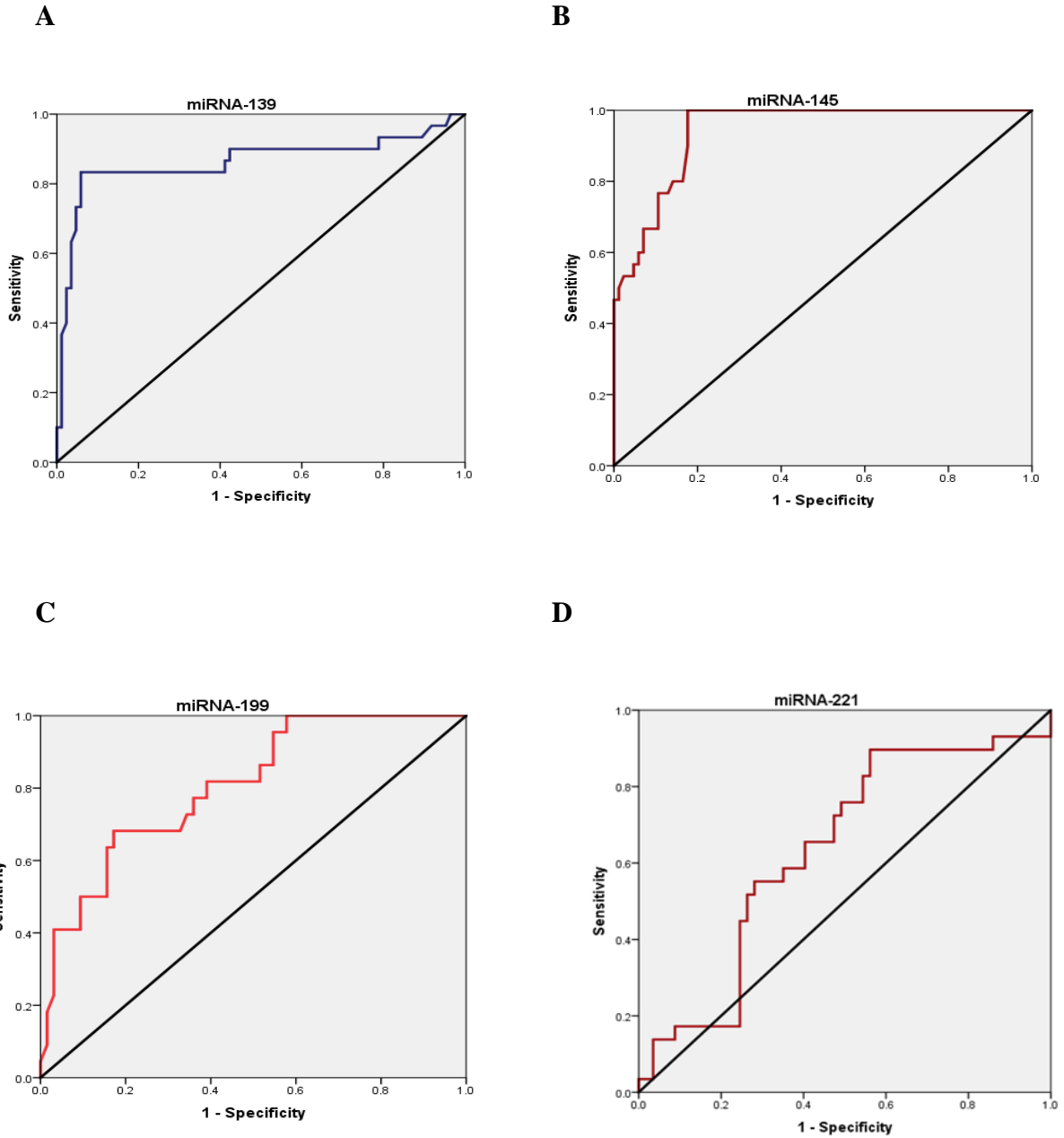

Figure 21. ROC Curves- Part 2. Receiver operator characteristic (ROC) curve analysis displaying the diagnostic power of the miRNAs studied in the hepatocellular carcinoma (HCC) group. Specificities and sensitivities were calculated from the ROC curves, in order to determine which of the miRNAs can be used for diagnosis and which is important for screening.

D. Correlations

The relationship between certain miRNAs of the 8 investigated, was assessed among the three patient groups (CHC, LC, and HCC) using the Pearson correlation. Certain pairs of miRNAs within the same patient group or between two different groups, yielded the Pearson correlation coefficient, r , which is a value ranging from +1 to -1 indicating whether the correlation between the two certain miRNAs is a positive or negative correlation.

Table 6. The correlation between miR-16 and miR-34a in the three patient groups

| | | HCC16 | LC16 | CHC16 | CHC34a | LC34a | HCC34a |
|--------|---------------------|-------|--------------|--------------|-------------------|-------|--------|
| HCC16 | Pearson Correlation | | | | $r = -0.668^{**}$ | | |
| | Sig. (2-tailed) | | | | .001 | | |
| LC16 | Pearson Correlation | | | | | | |
| | Sig. (2-tailed) | | | | | | |
| CHC16 | Pearson Correlation | | | | 0.722^{**} | | |
| | Sig. (2-tailed) | | | | 0.000 | | |
| LC34a | Pearson Correlation | | 0.705^{**} | | | | |
| | Sig. (2-tailed) | | 0.000 | | | | |
| HCC34a | Pearson Correlation | | | 0.520^{**} | | | |
| | Sig. (2-tailed) | | | 0.013 | | | |

MiR-16 in the HCC group was shown to be negatively correlated with miR-34a in the CHC group. Positive correlation has been shown in the CHC group between miR-16 and miR-34a, in the LC group between miR-16 and miR-34a, and in the HCC group for miR-34a and CHC group for miR-16.

Table 7. The correlation between miR221, miR-122a, and miR-125a in the three patient groups

| | | CHC221 | LC221 | HCC221 | CHC122a | LC122a | HCC122a | CHC125a | LC125a | HCC125a |
|---------|---------------------|--------|-----------------|--------|---------|----------------|----------------|----------------|-----------------|-----------------|
| CHC221 | Pearson Correlation | | 0.629** | | | | r=0.508* | | | |
| | Sig. (2-tailed) | | <i>p</i> <0.001 | | | | <i>p</i> <0.01 | | | |
| LC221 | Pearson Correlation | | | | | | | | -0.765** | |
| | Sig. (2-tailed) | | | | | | | | <i>p</i> <0.000 | |
| CHC122a | Pearson Correlation | | | | | | | | | 0.598** |
| | Sig. (2-tailed) | | | | | | | | | <i>p</i> <0.001 |
| LC122a | Pearson Correlation | | | | | | | -0.452* | | |
| | Sig. (2-tailed) | | | | | | | <i>p</i> <0.05 | | |
| CHC125a | Pearson Correlation | | | | | -0.452* | | | | 0.489* |
| | Sig. (2-tailed) | | | | | <i>p</i> <0.05 | | | | <i>p</i> <0.05 |

Negative correlations were shown between miR-221 and miR-125a in the LC group, and miR-122a in the LC group and miR-125a in the CHC group. miR-221 in the LC and CHC groups, miR-122a in the HCC group and miR-221 in the CHC group, miR-125a in HCC and miR-122a in CHC, and miR-125a in HCC and CHC groups, were all positively correlated.

Table 8. The correlation between miR139, miR-145, and miR-199a in the three patient groups

| | | CHC139 | LC139 | HCC139 | CHC145 | LC145 | HCC145 | CHC199a | LC199a | HCC199a |
|--------|---------------------|--------|-------|--------|--------|-------|----------|----------|----------|---------|
| CHC139 | Pearson Correlation | | | | | | r=0.492* | | | |
| | Sig. (2-tailed) | | | | | | 0.020 | | | |
| HCC139 | Pearson Correlation | | | | | | | | -0.577** | |
| | Sig. (2-tailed) | | | | | | | | 0.005 | |
| LC145 | Pearson Correlation | | | | | | | r=0.532* | | |
| | Sig. (2-tailed) | | | | | | | 0.011 | | |
| HCC145 | Pearson Correlation | 0.492* | | | | | | | | |
| | Sig. (2-tailed) | 0.020 | | | | | | | | |
| LC199a | Pearson Correlation | | | | | | | | | |
| | Sig. (2-tailed) | | | | | | | | | |

*Correlation is significant at the 0.05 level

**Correlation is significant at the 0.01 level

MiR-199a in the LC group and miR-139 in HCC were the only two groups negatively correlated. On the other hand, the positively correlated groups were, miR-145 in HCC and miR-139 in CHC, and miR-199a in CHC and miR-145 in LC.

VIII. DISCUSSION

HCV infection is a serious global health issue. It has been estimated that more than 80 million individuals suffer from HCV chronic infection worldwide, and that 3-4 million new cases are infected annually, in addition to approximately 350,000 HCV-related deaths. Egypt is known to be the country with the highest prevalence of HCV infection worldwide, with genotype 4 being the most common (Mahmoud *et al.*, 2013; Kandeel *et al.*, 2017). In 2008, the Egyptian government conducted the Egyptian Demographic Health Survey (EDHS) on a big nationally representative sample, which estimated the incidence among the 15-59 years age group of HCV antibodies as well as HCV RNA to be 14.7 and 9.8%; respectively. According to the population survey and the EDHS conducted in 2008, it was predicted that more than 6.8 million patients between the age of 15-59 years had HCV antibodies, out of which more than 4.5 million patients showed active HCV infection (Kandeel *et al.*, 2017). HCV infection is mainly asymptomatic with only minor symptoms at the acute stage of the disease. HCV infection usually results in fibrosis, cirrhosis, eventually leading to the development of HCC (Elgharably *et al.*, 2017).

HCC represents a major health issue worldwide, which is characterized by varied prognosis as well as its biological and clinical heterogeneity, due to different management approaches (Cabibbo *et al.*, 2016). HCC is still an extremely poor prognostic cancer that remains one of the most common and aggressive human malignancies worldwide. The early diagnosis of HCC is of great clinical desirability, since it promises good prognosis if the patient could get early surgical treatment. Currently, α -AFP is one of the main biomarkers used clinically for diagnosing primary HCC; however, its sensitivity and specificity are not satisfying (Aubé *et al.*, 2017); therefore, novel non-invasive biomarkers for early HCC diagnosis are greatly needed.

Research from recent studies revealed that circulating miRNAs are potential diagnostic biomarkers and prognostic factors in various kinds of diseases, especially in the field of cancer. Mitchell *et al.* (2008) demonstrated the presence of circulating tumor-derived miRNAs in blood by using a mouse prostate cancer xenograft model system, in which he showed measurements obtained from plasma were strongly correlated with those obtained from sera, suggesting that both serum and plasma samples would be adequate for measuring specific miRNA expression levels. In another study, Chen *et al.* (2008) demonstrated that by using serum directly or by

extracting RNA from the serum, it is possible to identify unique miRNA expression profiles for lung cancer, colorectal cancer and diabetic patients compared with healthy subjects. Circulating miRNAs have also been postulated as novel biomarkers for ovarian cancer (Resnick *et al.*, 2009; Taylor, 2008), pancreatic cancer (Ho *et al.*, 2010), and colorectal cancer (Huang *et al.*, 2010; Ng *et al.*, 2009). Although the clinical significance of these findings has not been elucidated in detail, those findings demonstrated that circulating miRNAs could be used as non-invasive diagnostic or prognostic biomarkers for cancer.

Several studies have demonstrated the significant association of miR-16 in hepatocarcinogenesis, Qu *et al.* (2011) showed that when combining miR-16 expression with the traditional liver biomarkers, the diagnostic accuracy is highly improved. As was shown in the results, miR-16 was significantly up-regulated in the HCC patient group. However, according to Qu *et al.* miR-16 is down-regulated in HCC patients, in which HCV infection was the underlying etiology in the study subjects. In 2014, Ge *et al.* also showed that miR-16 is down-regulated in the sera of HCC patients, which in combination with let-7f and miR-21 they can be used biomarkers for estimating the tumor size as well as recurrence (Ge *et al.*, 2014). As a matter of fact, in 2009 Huang *et al.* revealed through microarray analysis that miR-16 was up-regulated in HCC patients with mixed etiologies compared to normal subjects (Huang *et al.*, 2009).

Also, unlike what has been described in the literature, in the current study, miR-34a was up-regulated in HCC patients compared to the healthy subjects. Both Miao *et al.* (2014) and Yu *et al.* (2014) have shown that miR-34a was down-regulated in HCC. The conflicting results between the current study and what has been published in the literature might be attributed to a number of factors that impact the expression pattern of miRNAs in different studies. Such factors include the heterogeneity of the cancer patients, such as the tumor stage, treatment, and etiology. The type of specimen is also a major factor since different samples are continuously studied, like serum, plasma, paraffin-embedded tissue, or formalin-fixed tissue (Shen *et al.*, 2016). Additionally, the differences in sample collection, processing, and preservation are all factors that might impact the outcome of the expression analysis. Different RNA isolation techniques, the quality and concentration of the isolated RNA, and the detection methods, are all additional factors that might impact the miRNA expression profile. Even if the study was meticulously designed, using various methods and housekeeping transcripts for miRNA expression

normalization might result in experimental bias and therefore yielding different miRNA expression profiles. Thus, normalization is essential in eliminating most of the non-biological variations in order to ensure accurate miRNA expression profiles (Shen *et al.*, 2016).

In the current study, miR-221 was up-regulated as well with a sensitivity and specificity of 90.32 and 81.82; respectively. MiR-221 is known to be up-regulated in HCC and it plays important roles in hepatocarcinogenesis, responsible for proliferation, migration and invasion, apoptosis, clonogenicity, and G1 arrest, while targeting the following genes: *BMF*, *BBC3*, and *ANGPTL2* (Shen *et al.*, 2010). In 2011, Li *et al.* demonstrated that miR-221 was highly expressed in the sera of HCC patients; however, it was concluded that it was not statistically significant and might not serve as a reliable diagnostic biomarker for HCC (Li *et al.*, 2011). On the other hand, Turchinovich *et al.* (2011) showed that the up-regulation of miR-221 in the sera of HCC patients was associated with decreased survival rate.

The expression of miRNA-122a is specific to the liver, in which it is considered 70% of the entire miRNA expression in the liver. Current studies have shown that the expression levels of miRNA-122a have declined during the process of hepatocarcinogenesis; hence miRNA-122a can function as a tumor suppressor. Our findings were consistent with previous studies (Luo *et al.*, 2013; Ezzat *et al.*, 2014; Motawi *et al.*, 2016), in which we observed decline in the levels of miRNA-122a in HCC patients with HCV infection compared to the control individuals. On the other hand, the levels of miRNA-122a increased significantly in the CHC and LC groups suggesting that during the process of hepatocyte injury miRNA-122a levels increase drastically, and then decline significantly after the liver has entered carcinogenesis. On the contrary, according to a study by Jiang *et al.* (2015), the serum levels of miRNA-122a have been shown to be elevated in HCC patients compared to healthy individuals. Also, as presented in our results, the ROC curve has demonstrated that out of the eight miRNAs investigated, miRNA-122a has the highest specificity and sensitivity making it an eligible candidate as a liver tumor marker.

Coulouarn *et al.* (2009) showed that the overall survival of patients with high and low expression of miR-122a was 83.7 ± 10.3 and 30.3 ± 8.0 months, respectively, while the inhibition of miR-122a was also associated with low status of differentiation and large tumor size. Halász *et al.* (2015) revealed a reduced level of miR-122a in stage F4 fibrosis as compared

to stage F0, in which miR-122a showed a negative correlation with fibrosis stage in fibrotic liver samples and intriguingly, also with liver stiffness (LS) values. These findings are supported by reports of a negative correlation between miR-122a and fibrotic stage in chronic HCV infection, HCV-based HCC, and cirrhosis (Marquez *et al.*, 2010; Morita *et al.*, 2011), in addition to observations of a decreased level of miR-122a in non-alcoholic fatty liver disease (NAFLD) (Kerr *et al.*, 2011; Lakner *et al.*, 2011) and in HCC studies (Borel *et al.*, 2012).

Loss of miR-122a seems to be a frequent event in hepatoblastoma (Gyugos *et al.*, 2014), which correlates with migration, invasion and *in vivo* tumorigenesis, whereas HCC cells expressing miR-122a retain an epithelial phenotype (Karakatsanis *et al.*, 2013). MiR-122a is considered a differentiation marker for hepatocytes (Cairo *et al.*, 2010) and a lower level of miR-122a might also reflect a lower degree of differentiation in the embryonal component. In addition, reduced expression of miR-122a is essential for the normal function of hepatocytes; which positively regulates cholesterol, triglyceride accumulation, and fatty acid metabolism (Hu *et al.*, 2012), constituting 70% of the total miRNA pool of the liver.

The majority of studies that focused on the expression profiles of miRNA in HCC have shown that in most cases the progression of the malignancy is correlated with the down-regulation of the miRNAs. However, it needs to be taken into consideration that at the post-transcriptional level, miRNAs regulate hundreds of targets that are part of many signal transduction pathways, which makes the role of miRNAs in the process of hepatocarcinogenesis very complicated. Bi *et al.* (2012) showed that the expression of miR-125a is lower in HCC malignant tissue compared to non-tumor adjacent liver tissue, and that the low expression level of miR-125a was associated with the progression of the disease as well as poor prognosis. In addition to the lower expression observed in tissues, also low expression of miR-125a was seen in HCC cell lines. In fact, it has been shown that the *in vitro* and *in vivo* ectopic expression of miR-125a can lead to inhibition of proliferation, migration, and invasion of the HCC cells (Bi; *et al.*, 2012).

Unlike what the literature and other studies have shown, the expression level of miR-125a in our study was significantly higher in the HCC patient samples compared to the control group, which might be due to the fact that HCC was a result of a genotype 4 HCV infection. In addition,

the ancestral background and the gene pool of the current study is different than that of the other studies that demonstrated the down-regulation of miR-125a. Therefore, factors such as the genotype of HCV as well as the ancestral background of the study group might have had an impact on the expression profile of miR-125a. On the other hand, very high expression levels of miR-125a were observed in the CHC and LC patient groups. However, very low expression of miR-125a was reported in the HCC group, 29.96 ± 0.57 , compared to that of the CHC and LC groups, 96.01 ± 4.36 and 100.54 ± 0.81 ; respectively. Same as miR-122a, miR-125a showed high sensitivity and specificity, 86.67 and 83.33; respectively, suggesting its diagnostic value. Therefore, both miR-122a and miR-125a can be used together for the early detection of HCC induced HCV due to their high sensitivities and specificities.

Same as miR-125a, according to previous studies the expression level of miR-139 has been shown to be significantly lower in HCC patient samples compared to control individuals. MiR-139 was shown to play an important role in the hepatocarcinogenesis, in fact high expression levels of miR-139 were shown to inhibit cellular proliferation and invasion in malignant liver cells. In addition, in miR-139 transfected cells, apoptosis was shown to be highly induced, which suggests that miR-139 can act as a tumor suppressor through the inhibition of cell proliferation and invasion in HCC (Gu, Li, & Wang, 2014; Wang *et al.*, 2014). As shown in our results, the expression levels of miR-139 have increased in the HCC patient group compared to the control group, which contradicts what has been reported in other studies, while the CHC and LC patient groups showed significant increase of miR-139 expression. As a matter of fact, a possible explanation for the elevated expression levels for miR-125a and miR-139 in the HCC patient group can be due to the fact that HCV infection is the underlying cause for the HCC patients in the study, which might have an effect on the expression level of the two miRNAs. Although according to the literature, the HCV infection should not be affecting the expression levels after the patient develops HCC; however, no study has examined that with HCV genotype 4. All patients in our study have developed HCC as a result of a genotype 4 HCV infection, which may have resulted in the high expression level of miR-125a and miR-139 contradicting other studies. As a matter of fact, since tumor cells are smaller in number compared to the rest of the cells in the body, most of the changes in the expression levels of specific circulating miRNAs result from

the body's response to carcinogenesis, thus making it difficult to generate unique miRNA signatures for the detection of specific types of tumors (Qi *et al.*, 2016).

MiR-145, was another miRNA tested among the miRNAs panel investigated, in which its expression level showed no difference between the normal controls and the HCC patient group. Same as the rest of the miRNAs investigated, miR-145 in the CHC and LC groups showed significant increase compared to the control and HCC groups. Among several studies, Wang *et al.* (2014) demonstrated that miR-145 was significantly down-regulated in HCC patient samples as well as HCC cell lines. As a matter of fact, the down-regulation of miR-145 was greatly linked to intrahepatic metastasis, tumor size, vascular invasion, and tumor grade, all suggesting that miR-145 acts as tumor suppressor and its decreased expression results in the progression of the hepatocarcinogenesis (Wang *et al.*, 2014; Yang *et al.*, 2014). Therefore, determining the tumor size and grade in the HCC patients enrolled in the current study will be a key factor in understanding the such contradicting expression profiles between what has been reported in the literature versus the current study.

The last miRNA we investigated was miR-199a, which was down-regulated in the HCC patient group compared to the control group, while it was significantly upregulated in the CHC and LC groups. The down regulation of miR-199a has been reported in several studies; in fact, miR-199a has been one of the most consistently reported miRNAs to be involved in HCC. MiR-199a is the third highly expressed miRNA in the liver, and in the case of HCC it has been shown to be down-regulated especially in patients with HCV, HBV infections, and alcohol abuse (Diaz *et al.*, 2013). The down-regulation of miR-199a in HCC patients has been associated with poor prognosis. The identification of miRNAs associated with HCC is crucial to developing new diagnostic and therapeutic tools with high specificity and sensitivity in order to combat this vicious human cancer.

Correlation is a technique often used to study the relationship between two quantitative and continuous variables. In the current study, we used Pearson correlation to calculate the Pearson's correlation coefficient (R), a value between +1 and -1 that indicates the strength of the association between two variables (Chen *et al.*, 2008). The correlation between miR-16 and miR-34a was investigated among the three patient groups, in which miR-34a and miR-16 in CHC and

LC were positively correlated as well as miR-34a in HCC and miR-16 in CHC. On the other hand, miR-34a in CHC and miR-16 in HCC showed a highly significant negative correlation. More positive correlations were shown among the following groups: miR-221 in LC and CHC, miR-122a in HCC and miR-221 in CHC, miR-125a in HCC and miR-122a in CHC, miR-125a in HCC and CHC, indicating for example if there is low expression of miR-122a in HCC, then miR-221 will be down-regulated as well in CHC. miR-125a in CHC and miR-122a in LC, and miR-125a and miR-122a in LC were shown to be negatively correlated, meaning that if one is over-expressed the other will automatically show a decreased expression. Finally, miR-145 in HCC and miR-139 in CHC as well as miR-199a in CHC and miR-145 in LC were positively correlated, while miR-199a in LC and miR-139 in HCC were negatively correlated. Establishing the Pearson correlation between different miRNAs among the patient groups has a significant diagnostic value because it indicates if two miRNAs were for example positively correlated in one or more patient group, then only one of these miRNAs is needed to be investigated. For example, in the CHC group, the r value for the correlation between miR-34a and miR-16 was shown to have a positive correlation of 0.722, which means that if miR-34a is up-regulated, then miR-16 will be up-regulated as well, and vice versa. Therefore, from a diagnostic perspective, if for instance miR-34a was found to be elevated, then it can be inferred that miR-16 will be elevated as well.

Finally, circulating miRNAs in liver cancer patients represent promising biomarkers that possess great stability and reproducibility in peripheral blood. MiRNAs have the potential to be used in several clinical aspects of cancer management, such as cancer screening and early diagnosis, evaluating the malignancy in order to choose a surgical or a non-surgical approach, and to check for recurrence and cancer dynamics (Kawaguchi *et al.*, 2016). Additionally, circulating miRNAs can be versatile, as it is anticipated that they will be used as efficient therapeutic agents in human tumors. MiRNAs possess a major advantage as therapeutic agents, which is the fact that a single miRNA targets several genes that function in the same pathway (Aqeilan *et al.*, 2010). Due to their non-invasive and reproducible nature, it is anticipated that in the future circulating miRNAs will be efficient biomarkers and reliable indicators in pretreatment options.

IX. CONCLUSION

As was shown in the results, measurement of serum levels of miR-122a, miR-125a, miR-139, miR-145, and miR-199a can help to differentiate HCC from CHC and LC. The serum levels of miRNA-122a, miRNA-125a, miRNA-139, miRNA-145 and miRNA-199a were significantly lower ($p < 0.01$) in HCC than in both CHC and LC groups; therefore, this panel of miRNAs provide high accuracy for the early detection of HCC. On the other hand, measurement of serum levels of miR-16, miR-34a, and miR-221 were shown to have a prognostic rather than a diagnostic value since they did not significantly differentiate the HCC group from the CHC and LC groups. Moreover, according to their expression patterns among the patient groups, miR-16, miR-34a, and miR-221, can be used to detect liver injury, such as fibrosis and cirrhosis, due to their significant elevation in comparison to the control subjects. Additionally, highly significant correlation was established between different miRNAs within the same patient group or between two different groups, indicating a diagnostic potential for the early detection of HCC. MiR-122a showed the highest specificity and sensitivity, indicating that serum miR-122a is a novel and potential non-invasive biomarker for HCV-induced HCC. Finally, following miR-122a, miR-125a was shown to be a great potential HCC biomarker as well since it showed the second highest specificity, indicating its significance in diagnosis, but not in screening due to the low sensitivity.

X. FUTURE PERSPECTIVES

After years of extensive research, there is no doubt that miRNAs play a critical role in carcinogenesis and control the development and progression of human cancers. Although scientists in the last decade have managed to answer a lot of questions regarding the contribution of miRNA to carcinogenesis, there still remains number of unanswered questions before using miRNA profiling in the clinical practice. One of the major challenges that will be faced in the future is establishing specific cancer miRNA signatures that are extremely reproducible and independently predictive of the tumor in order to improve cancer diagnosis and therapy (Leva & Croce, 2013). Therefore, major research is being conducted to overcome such challenges in order to utilize miRNAs as an accurate diagnostic tool for the early detection of human cancers as well as an effective therapeutic tool.

Using circulating miRNAs as biomarkers in cancer patients presents several challenges. First of all, the expression profile of a single miRNA cannot be used as a biomarker of one specific tumor, due to the fact that several miRNAs are highly expressed in more than one tumor as well as other diseases. Several miRNAs display opposite expression patterns in different types of cancers, such as the family of miR-200 (Kawaguchi *et al.*, 2016). Therefore, using the expression patterns of several miRNAs rather than one and different miRNA signatures might serve as a more reliable biomarker depending on which tumor type is being diagnosed. Large-scale studies with well-defined methods are in demand in order to clinically implement the use of circulating miRNAs in diagnosing patients with liver cancer (Kawaguchi *et al.*, 2016).

In order to establish an accurate diagnostic tool using miRNAs, the diagnostic panel should include the following (Qi *et al.*, 2016 & Carter *et al.*, 2017):

- 1) Unique miRNA signatures with specificity and sensitivity for each type of human cancer
- 2) Precise variations triggered by extrinsic and intrinsic factors
- 3) Specific procedures for standard normalization along with accurate internal controls
- 4) Well-defined reference range of specific circulating miRNAs in healthy individuals
- 5) Specified concentration kinetics of individual circulating miRNAs

XI. REFERENCES

- Abdel-Misih SR & Bloomston M. (2010). Liver Anatomy. *Surg Clin North Am*, 90(4): 643-653.
- Alazawi W, Cunningham M, Dearden J, & Foster GR. (2010). Systematic review: outcome of compensated cirrhosis due to chronic hepatitis C infection. *Aliment Pharmacol Ther.*, 32(3): 344–355.
- Antonini D, Russo MT, De Rosa L, Gorrese M, Del Vecchio L, & Missero C. (2010). Transcriptional repression of MiR-34 family contributes to p63-mediated cell cycle progression in epidermal cells. *J Invest Dermatol*, 130: 1249–1257.
- Aqeilan RI, Calin GA, & Croce CM. (2010). miR-15a and miR-16-1 in cancer: discovery, function, and future perspectives. *Cell Death Differ*, 17: 215-220.
- Arafa N, El Hoseiny M, Rekacewicz C, Bakr I, El-Kafrawy S, El Daly M, *et al.* (2005). Changing pattern of hepatitis C virus spread in rural areas of Egypt. *J. Hepatol.*, 43(3): 418–424.
- Attiyeh EF, London WB, Mosse YP, Wang Q, Winter C, Khazi D, *et al.* (2005). Children’s oncology Group. Chromosome 1p and 11q deletions and outcome in neuroblastoma. *N Engl J Med*, 24: 2243–2253.
- Aubé C, Oberti F, Lonjon J, Pageaux G, Seror O, N’Kontchou G, *et al.* (2017). EASL and AASLD recommendations for the diagnosis of HCC to the test of daily practice. *Liver Int.*, doi: 10.1111/liv.13429
- Bandiera S, Pfeffer S, Baumert TF, & Zeisel MB (2015). MiR-122 – A key factor and therapeutic target in liver disease. *J. Hepatol*, 62: 448-457.
- Barger JF, Rahman MA, Jackson D, Acunzo M, & Nana-Sinkam SP (2016). Extracellular miRNAs as biomarkers in cancer. *Food Chem Toxicol*, 98: 66-72.
- Befeler AS & Di Bisceglie AM. (2002). Hepatocellular carcinoma: diagnosis and treatment. *Gastroenterology*, 122(6):1609–1619.
- Bertuccio P, Bosetti C, Levi F, Decarli A, Negri E, & La Vecchia C. (2013). A comparison of trends in mortality from primary liver cancer and intrahepatic cholangiocarcinoma in Europe. *Ann Oncol*; 24: 1667-1674
- Bi Q, Tang S, Xia L, Du R, Fan R, Gao L, *et al.* (2012). Ectopic Expression of MiR-125a Inhibits the Proliferation and Metastasis of Hepatocellular Carcinoma by Targeting MMP11 and VEGF. *PLoS One*, 7(6): e40169.
- Blagg W, Schloegel EL, Mansour NS, & Khalaf GI. (1955). A new concentration technic for the demonstration of Protozoa and Helminth Eggs in Feces. *Am J Trop Med Hyg*, 4(1): 23-8.

- Bogdanos DP, Gao B, & Gershwin ME (2013). Liver Immunology. *Compr Physiol*, 3(2): 567-598.
- Bolondi L, Sofia S, Siringo S, Gaiani S, Casali A, Zironi G, *et al.* (2001). Surveillance programme of cirrhotic patients for early diagnosis and treatment of hepatocellular carcinoma: a cost effectiveness analysis. *Gut*, 48(2): 251-259
- Bommer GT, Gerin I, Feng Y, Kaczorowski AJ, Kuick R, Love RE, *et al.* (2007). p53-mediated activation of miRNA 34 candidate tumor-suppressor genes. *Curr. Biol.*, 17(15): 1298–1307.
- Borel F, Konstantinova P, & Jansen PL (2012) Diagnostic and therapeutic potential of miRNA signatures in patients with hepatocellular carcinoma. *J Hepatol.*, 56 (6):1371-1383.
- Bosetti C, Bianchi C, Negri E, Colombo M, & La Vecchia C. (2009). Estimates of the incidence and prevalence of hepatocellular carcinoma in Italy in 2002 and projections for the years 2007 and 2012. *Tumori*; 95(1): 23-27
- Bosetti C, Levi F, Boffetta P, Lucchini F, Negri E, & La Vecchia C. (2008). Trends in mortality from hepatocellular carcinoma in Europe, 1980-2004. *Hepatology*, 48(1): 137-145
- Bottoni A, Piccin D, Tagliati F, Luchin A, Zatelli MC, & degli Uberti EC. (2005). miR-15a and miR-16-1 down-regulation in pituitary adenomas. *J Cell Physiol*, 204: 280–285.
- Bruix J, Gores GJ, & Mazzaferro V. (2014). Hepatocellular Carcinoma: Clinical Frontiers and Perspectives. *Gut*, 63(5): 844:855.
- Bruix J, Sherman M, & American Association for the Study of Liver Diseases (2011). Management of hepatocellular carcinoma: an update. *Hepatology*, 53(3): 1020-1022
- Cabibbo G, Reig M, Gadaleta-Caldarola G, Galati G, Lombardi G, Mazza G, *et al.* (2016). The calm before the storm: a report from the International Liver Cancer Association congress 2015-part 1. *Future Oncol.*, 12(3): 281-4.
- Cairo S, Wang Y, de Reyniès A, Duroure K, Dahan J, Redon MJ, *et al.* (2010). Stem cell-like micro-RNA signature driven by Myc in aggressive liver cancer. *Proc Natl Acad Sci U S A*, 107(47): 20471–6.
- Calin GA & Croce CM. (2006). Genomics of chronic lymphocytic leukemia microRNAs as new players with clinical significance. *Semin Oncol*, 33: 167–173.
- Calin GA, Dumitru CD, Shimizu M, Bichi R, Zupo S, Noch E, *et al.* (2002). Frequent deletions and down-regulation of micro-RNA genes miR-15 and miR-16 at 13q14 in chronic lymphocytic leukemia. *Proc Natl Acad Sci U S A*, 99(24): 15524-9.

- Capurro M, Wanless IR, Sherman M, Deboer G, Shi W, Miyoshi E, *et al.* (2003). Glypican-3: a novel serum and histochemical marker for hepatocellular carcinoma. *Gastroenterology*, 125(1): 89-97.
- Carter JV, Galbraith NJ, Yang D, Burton JF, Walker SP, & Galandiuk S. (2017). Blood-based microRNAs as biomarkers for the diagnosis of colorectal cancer: a systematic review and meta-analysis. *Br J Cancer*, 116(6): 762-774.
- Chan KY, Wong CM, Kwan JS, Lee JM, Cheung KW, Yuen MF *et al.* (2011). Genome-wide association study of hepatocellular carcinoma in Southern Chinese patients with chronic hepatitis B virus infection. *PLoS One*, 6(12): e28798.
- Chang TC, Wentzel EA, Kent OA, Ramachandran K, Mullendore M, Lee KH, *et al.* (2007). Transactivation of miR-34a by p53 broadly influences gene expression and promotes apoptosis. *Mol Cell*, 26(5): 745–752.
- Cheloufi S, Dos SC, Chong MM, & Hannon GJ. (2010). A dicer-independent miRNA biogenesis pathway that requires Ago catalysis. *Nature*, 465(7298):584–589.
- Chen X, Ba Y, Ma L, Cai X, Yin Y, Wang K, *et al.* (2008). Characterization of microRNAs in serum: a novel class of biomarkers for diagnosis of cancer and other diseases. *Cell Res*, 18(10): 997–1006.
- Chu R, Mo G, Duan Z, Huang M, Chang J, Li X, *et al.* (2014). miRNAs affect the development of hepatocellular carcinoma via dysregulation of their biogenesis and expression. *Cell Commun Signal*, 12: 45.
- Cifuentes D, Xue H, Taylor DW, Patnode H, Mishima Y, Cheloufi S, *et al.* (2014). A novel miRNA processing pathway independent of Dicer requires Argonaute2 catalytic activity. *Science*, 328(5986):1694–8.
- Cimmino A, Calin GA, Fabbri M, Iorio MV, Ferracin M, Shimizu M, *et al.* (2005). miR-15 and miR-16 induce apoptosis by targeting BCL2. *Proc Natl Acad Sci USA*, 102: 13944–13949.
- Colli A, Fraquelli M, Casazza G, Massironi S, Colucci A, Conte D, *et al.* (2006). Accuracy of ultrasonography, spiral CT, magnetic resonance, and α -fetoprotein in diagnosing hepatocellular carcinoma: a systematic review. *Am J Gastroenterol*, 101(3): 513-23.
- Coulouarn C, Factor VM, Andersen JB, Durkin ME, & Thorgeirsson SS. (2009). Loss of miR-122 expression in liver cancer correlates with suppression of the hepatic phenotype and gain of metastatic properties. *Oncogene*, 28(40): 3526–36.
- Coulouarn C, Factor VM, Andersen JB, Durkin ME, & Thorgeirsson SS. (2009). Loss of miR-122 expression in liver cancer correlates with suppression of the hepatic phenotype and gain of metastatic properties. *Oncogene*, 28: 3526–3536.

- Cui S-Y, Wang R, & Chen L-B. (2014). MicroRNA-145: a potent tumor suppressor that regulates multiple cellular pathways. *J Cell Mol Med*, 18(10): 1913–1926.
- Dang Y, Dianzhong L, Rong M, & Chen G. (2013). Under expression of miR-34a in hepatocellular carcinoma and its contribution towards enhancement of proliferating inhibitory effects of agents targeting c-MET. *PLoS One*, 8(4): e61054.
- Davila JA, Morgan RO, Richardson PA, Du XL, McGlynn KA, & El-Serag HB. (2010). Use of surveillance for hepatocellular carcinoma among patients with cirrhosis in the United States. *Hepatology*, 52: 132-141.
- De Palma M, Coukos G, & Semela D. (2013). TIE2-expressing monocytes: a novel cellular biomarker for hepatocellular carcinoma? *Hepatology*, 57(4): 1294-6.
- Deng X-G, Qiu R-L, Wu Y-H, Li Z-X, Xie P, Zhang J, *et al.* (2014). Overexpression of miR-122 promotes the hepatic differentiation and maturation of mouse ESCs through a miR-122/FoxA1/HNF4a-positive feedback loop. *Liver Int*, 34:281–295.
- Denli AM, Tops BB, Plasterk RH, Ketting RF, & Hannon GJ. (2004). Processing of primary microRNAs by the Microprocessor complex. *Nature*, 432: 231–235.
- Dhanasekaran R, Limaye A, & Cabrera R. (2012). Hepatocellular carcinoma: current trends in worldwide epidemiology, risk factors, diagnosis, and therapeutics. *Hepat Med*, 4: 19-37.
- Di Bisceglie, Adrian, Sterling RK, Chung RT, Everhart JE, Dienstag JL, Bonkovsky HL, *et al.* (2005). Serum α -fetoprotein levels in patients with advanced hepatitis C: results from the HALT-C Trial. *J Hepatol*; 43(3): 434-441.
- Di Leva G & Croce CM. (2013). MiRNA profiling of cancer. *Curr Opin Genet Dev*, 23(1): 3-11.
- Di Martino MT, Rossi M, Caracciolo D, Gullà A, Tagliaferri P, Tassone P (2016). Mir-221/222 are promising targets for innovative anticancer therapy. *Expert Opin Ther Targets*, 20(9): 1099-108.
- Diaz G, Melis M, Tice A, Kleiner DE, Mishra L, Zamboni F, *et al.* (2013). Identification of microRNAs specifically expressed in hepatitis C virus-associated hepatocellular carcinoma. *Int J Cancer*, 133(4): 816-24.
- Ding CL, Xu G, Ren H, Zhao LJ, Zhao P, Qi ZT, *et al.* (2015). HCV infection induces the upregulation of miR-221 in NF- κ B dependent manner. *Virus Res*, 196: 135-9.
- Ding J & Wang H. (2014). Multiple Interactive Factors in Hepatocarcinogenesis. *Cancer Lett*, 346(1): 17-23.

- El-Abd NE, Fawzy NA, El-Sheikh SM, & Soliman ME. (2015). Circulating miRNA-122, miRNA-199a, and miRNA-16 as Biomarkers for Early Detection of Hepatocellular Carcinoma in Egyptian Patients with Chronic Hepatitis C Virus Infection. *Mol Diagn Ther*, 19(4): 213-220.
- El-Ahwany E, Mourad L, Zoheiry M, Abu-Taleb H, Nagy F, Atta R, *et al.* (2015). Circulating miRNA-122 as a biomarker for HCV-induced hepatocellular carcinoma. Poster presented at the International Liver Cancer Association (ILCA) meeting, Paris, France.
- El-Ahwany E., Mourad L., Zoheiry M., Abu-Taleb H., Nagy F., Atta R., *et al.* (2017). Serum miRNAs as biomarkers for HCV-induced hepatocellular carcinoma in Egyptian patients. Manuscript submitted for publication.
- Elgharably A, Gomaa AI, Crossey MM, Norsworthy PJ, Waked I, & Taylor-Robinson SD (2017). Hepatitis C in Egypt- past, present, and future. *Int J of Gen Med*, 10: 1-6.
- El-Serag HB & Mason AC. (2000). Risk factors for the rising rates of primary liver cancer in the United States. *Arch Intern Med*, 160(21): 3227–30.
- El-Serag HB. (2004). Hepatocellular carcinoma: recent trends in the United States. *Gastroenterology*, 127(5): S27-S34
- El-Serag HB. (2011). Hepatocellular Carcinoma. *N Engl J Med*, 365(12): 1118-27.
- El-Shafei AZ. (1962). The evaluation of methods of parasitological diagnosis of bilharziasis. *Proc first Intern Symp Bilh Cairo*, part 1: 421.
- European Association For The Study Of The Liver & European Organisation For Research And Treatment Of Cancer. (2012). EASL-EORTC clinical practice guidelines: management of hepatocellular carcinoma. *J Hepatol*, 56(4): 908-43
- Ezzat H, Lotfy AM, Alalfy MN, El-Taher SM, Mokhtar A, Mohamed SA, *et al.* (2014). The significance of circulating Micro RNA-122 as a non-invasive diagnostic marker of liver injury in Egyptian chronic hepatitis C virus infected and cirrhotic patients with and without hepatocellular carcinoma. *Clinical Med Diagn*, 4(1): 1-8.
- Fattovich G, Giustina G, Degos F, Tremolada F, Diodati G, Almasio P, *et al.* (1997). Morbidity and mortality in compensated cirrhosis type C: a retrospective follow-up study of 384 patients. *Gastroenterology*, 112(2): 463–72.
- Fattovich G, Stroffolini T, Zagni I, & Donato F. (2004). Hepatocellular carcinoma in cirrhosis: incidence and risk factors. *Gastroenterology*, 127: S35-S50.
- Fornari F, Gramantieri L, Ferracin M, Veronese A, Sabbioni S, Calin G A, *et al.* (2008). MiR-221 controls CDKN1C/p57 and CDKN1B/p27 expression in human hepatocellular carcinoma. *Oncogene*, 27(43): 5651–61.

Frank C, Mohamed MK, Strickland GT, Lavanchy D, Arthur RR, Magder LS, *et al.* (2000). The role of parenteral antischistosomal therapy in the spread of hepatitis C virus in Egypt. *Lancet.*, 355(9207): 887–891.

Friedman SL. (2003). Liver Fibrosis – from bench to bedside. *J Hepatol*, 38: S38-S53.

Galardi S, Mercatelli N, Giorda E, Massalini S, Frajese GV, Ciafrè SA, *et al.* (2007). miR-221 and miR-222 expression affects the proliferation potential of human prostate carcinoma cell lines by targeting p27kip1. *J Biol Chem.*, 282(32): 23716–24.

Garofalo M, Quintavalle C, Romano G, Croce CM, & Condorelli G (2012). miR-221/222 in Cancer: Their Role in Tumor Progression and Response Therapy. *Curr Mol Med*; 12 (1): 27-33.

Ge W, Yu DC, Li QG, Chen X, Zhang CY, & Ding YT (2014). Expression of serum miR-16, let-7f, and miR-21 in patients with hepatocellular carcinoma and their clinical significances. *Clin Lab*, 60 (3): 427-34.

Giannelli G, Marinosci F, Trerotoli P, Volpe A, Quaranta M, Dentico P, *et al.* (2005). SCCA antigen combined with α -fetoprotein as serologic markers of HCC. *Int J Cancer*, 117(3): 506-509

Giannini EG, Cucchetti A, Erroi V, Garuti F, Odaldi F, & Trevisani F (2013). Surveillance for early diagnosis of hepatocellular carcinoma: How best to do it? *World J Gastroenterol*, 19(47): 8808-21.

Giannini EG, Marengo S, Borgonovo G, Savarino V, Farinati F, Del Poggio P, *et al.* (2012). Alpha-fetoprotein has no prognostic role in small hepatocellular carcinoma identified during surveillance in compensated cirrhosis. *Hepatology*, 56(4): 1371-9

Gomaa A, Allam N, Elsharkway A, El Kassas M, & Waked I. (2017). Hepatitis C infection in Egypt: prevalence, impact and management strategies. *Hepat Med*, 9: 17-25.

Gower E, Estes C, Blach S, Razavi-Shearer K, & Razavi, H (2014). Global epidemiology and genotype distribution of the hepatitis C virus infection. *J. Hepatol.* 61(1 Suppl): S45–S57.

Gramantieri L, Ferracin M, Fornari F, Veronese A, Sabbioni S, Liu CG *et al.* (2007). Cyclin G1 is a Target of miR-122a, a MicroRNA Frequently Down-Regulated in Human Hepatocellular Carcinoma. *Cancer Res*, 67(13): 6092–9.

Gregory RI, Yan KP, Amuthan G, Chendrimada T, Doratotaj B, Cooch N, *et al.* (2004). The Microprocessor complex mediates the genesis of microRNAs. *Nature*, 432: 235–240.

Gu W, Li X, & Wang J. (2014). miR-139 regulates the proliferation and invasion of hepatocellular carcinoma through the WNT/TCF-4 pathway. *Oncol Rep*, 31(1): 397-404.

- Gupta P, Cairns MJ, & Saksena NK (2014). Regulation of gene expression by microRNA in HCV infection and HCV-mediated hepatocellular carcinoma. *Virology*, 11: 64.
- Gupta S, Bent S, & Kohlwes J. (2003). Test characteristics of α -fetoprotein for detecting hepatocellular carcinoma in patients with hepatitis C. A systematic review and critical analysis. *Ann Intern Med*; 139(1): 46-50
- Gyugos M, Lendvai G, Kenessey I, Schlachter K, Halász J, Nagy P *et al.* (2014). MicroRNA expression might predict prognosis of epithelial hepatoblastoma. *Virchows Arch*, 464 (4): 419-27.
- Halász T, Horváth G, Pár G, Werling K, Kiss A, Schaff Z, *et al.* (2015). miR-122 negatively correlates with liver fibrosis as detected by histology and FibroScan. *World J Gastroenterol*, 21(25): 7814-7823.
- Hayes CN & Chayama K (2016). MicroRNAs as Biomarkers for Liver Disease and Hepatocellular Carcinoma. *Int J Mol Sci*, 17(3): 280.
- Hayes J, Peruzzi PP, & Lawler S. (2014). MicroRNAs in cancer: biomarkers, functions and therapy. *Trends in molecular medicine*, 20(8), 460-469.
- He L, He X, Lim LP, de Stanchina E, Xuan Z, Liang Y, *et al.* (2007). A microRNA component of the p53 Tumor suppressor network. *Nature*, 447(7148):1130-4.
- Hermeking H. (2010) The *miR-34* family in cancer and apoptosis. *Cell Death Differ*. 17(2): 193-9.
- Hikmet B, Reyhan B, Melda K, & Burcu A. (2016). MicroRNA nomenclature and the need for a revised naming prescription. *Brief Funct Genomics*, 15 (1): 65-71.
- Ho AS, Huang X, Cao H, Christman-Skieller C, Bennewith K, Le QT, *et al.* (2010). Circulating miR-210 as a Novel Hypoxia Marker in Pancreatic Cancer. *Transl Oncol*, 3(2): 109-13.
- Hoekstra LT, de Graaf W, Nibourg GA, Heger M, Bennink RJ, Stieger B, *et al.* (2013). Physiological and Biochemical Basis of Clinical Liver Function Tests. *Ann Surg*, 257(1): 27-36.
- Hsia CY, Huo TI, Chiang SY, Lu MF, Sun CL, Wu JC, *et al.* (2007). Evaluation of interleukin-6, interleukin-10 and human hepatocyte growth factor as tumor markers for hepatocellular carcinoma. *Eur J Surg Oncol*, 33(2): 208-212
- Hsu SH, Wang B, Kota J, Yu J, Costinean S, Kutay H, *et al.* (2012). Essential metabolic, anti-inflammatory, and anti-tumorigenic functions of miR-122 in liver. *J Clin Invest.*, 122(8): 2871-2883.
- Hu J, Xu Y, Hao J, Wang S, Li C, & Meng S (2012). MiR-122 in hepatic function and liver diseases. *Protein Cell*, 3(5): 364-71.

Huang XH, Wang Q, Chen JS, Fu XH, Chen XL, Chen LZ, *et al.* (2009). Bead-based microarray analysis of microRNA expression in hepatocellular carcinoma: miR-338 is downregulated. *Hepatol Res*, 39(8): 786-794.

Huang Z, Huang D, Ni S, Peng Z, Sheng W, & Du X. (2010). Plasma microRNAs are promising novel biomarkers for early detection of colorectal cancer. *Int J Cancer*, 127(1): 118–26.

Hussein MM, Ibrahim AA, Abdella HM, Montasser IF, & Hassan MI. (2008). Evaluation of serum squamous cell carcinoma antigen as a novel biomarker for diagnosis of hepatocellular carcinoma in Egyptian patients. *Indian J Cancer*, 45(4): 167-172

Ibrahim AS, Khaled HM, Nabil NM, Baraka H, & Kamel H. (2014). Cancer incidence in Egypt: results of the national population-based cancer registry program. *J Cancer Epidemiol*, 2014: 437971.

Ikoma J, Kaito M, Ishihara T, Nakagawa N, Kamei A, Fujita N, *et al.* (2002). Early diagnosis of hepatocellular carcinoma using a sensitive assay for serum des-gamma-carboxy prothrombin: a prospective study. *Hepato gastroenterology*, 49(43): 235-238

Ishii M, Gama H, Chida N, Ueno Y, Shinzawa H, Takagi T, *et al.* (2000). Simultaneous measurements of serum α -fetoprotein and protein induced by vitamin K absence for detecting hepatocellular carcinoma. South Tohoku District Study Group. *Am J Gastroenterol*, 95(4): 1036-40

Iwasaki YW, Kiga K, Kayo H, Fukuda-Yuzawa Y, Weise J, Inada T, *et al.* (2013). Global microRNA elevation by inducible Exportin 5 regulates cell cycle entry. *RNA*, 19(4): 490-7.

Jemal A, Bray F, Center MM, Ferlay J, Ward E, & Forman D. (2011). Global cancer statistics. *CA Cancer J Clin.*, 61(2): 69–90.

Jiang L, Cheng Q, Zhang BH, & Zhang MZ. (2015). Circulating microRNAs as biomarkers in hepatocellular carcinoma screening: A validation set from China. *Medicine (Baltimore)*, 94(10): e603.

Jiang L, Huang Q, Zhang S, Zhang Q, Chang J, Qiu X, *et al.* (2010). Hsa-miR-125a-3p and hsa-miR-125a are downregulated in non-small cell lung cancer and have inverse effects on invasion and migration of lung cancer cells. *BMC Cancer*, 10: 318.

Kandeel A, Genedy M, El-Refai S, Funk AL, Fontanet A, & Talaat M (2017). The prevalence of hepatitis C virus infection in Egypt 2015: implications for future policy on prevention and treatment. *Liver Int*, 37(1): 45-53.

Kanwal F, Hoang T, Kramer JR, Asch SM, Goetz MB, Zeringue A, *et al.* (2011). Increasing prevalence of HCC and cirrhosis in patients with chronic hepatitis C virus infection. *Gastroenterology*, 140(4): 1182-1188.e1

- Karakatsanis A, Papaconstantinou I, Gazouli M, Lyberopoulou A, Polymeneas G, & Voros D. (2013). Expression of microRNAs, miR-21, miR-31, miR-122, miR-145, miR-146a, miR-200c, miR-221, miR-222, and miR-223 in patients with hepatocellular carcinoma or intrahepatic cholangiocarcinoma and its prognostic significance. *Mol Carcinog.*, 52(4): 297–303.
- Kawaguchi T, Komatsu S, Ichikawa D, Tsujiura M, Takeshita H, Hirajima S, *et al.* (2016). Circulating MicroRNAs: A Next-Generation Clinical Biomarker for Digestive System Cancers. *Int J Mol Sci*, 17(9): pii: E1459.
- Kerr TA, Korenblat KM, & Davidson NO (2011). MicroRNAs and liver disease. *Transl Res*, 157(4): 241-52.
- Krützfeldt J, Rajewsky N, Braich R, Rajeev KG, Tuschl T, Manoharan M, *et al.* (2005). Silencing of microRNAs in vivo with “antagomirs”. *Nature*, 438: 685–689.
- Lakner AM, Bonkovsky HL, & Schrum LW. (2011). MicroRNAs: fad or future of liver disease. *World J Gastroenterol*, 17(20): 2536-42.
- Laudadio I, Manfroid I, Achouri Y, Schmidt D, Wilson MD, Cordi S, *et al.* (2012). A feedback loop between the liver-enriched transcription factor network and miR-122 controls hepatocyte differentiation. *Gastroenterology*, 142: 119–129.
- Lawrie CH, Gal S, Dunlop HM, Pushkaran B, Liggins AP, Pulford K, *et al.* (2008). Detection of elevated levels of tumor associated microRNAs in serum of patients with diffuse large B-cell lymphoma. *Br J Haematol*, 141(5): 672-5.
- Lederle FA & Pocha C. (2012). Screening for liver cancer: the rush to judgment. *Ann Intern Med*, 156: 387-389.
- Lee RC, Feinbaum RL, & Ambros V. (1993). The *C. elegans* Heterochronic Gene *lin-4* Encodes Small RNAs with Antisense Complementarity to *lin-4*. *Cell*, 75(5): 843-54.
- Lee Y, Ahn C, Han J, Choi H, Kim J, Yim J, *et al.* (2003). The nuclear RNase III Drosha initiates microRNA processing. *Nature*, 425: 415– 419.
- Li D, Mallory T, & Satomura S. (2001). AFP-L3: a new generation of tumor marker for hepatocellular carcinoma. *Clin Chim Acta*; 313(1-2): 15-19.
- Li J, Wang Y, Yu W, Chen J, & Luo J. (2011). Expression of serum miR-221 in human hepatocellular carcinoma and its prognostic significance. *Biochem Biophys Res Commun*; 406 (1): 70-73.
- Li N, Fu H, Tie Y, Hu Z, Kong W, Wu Y, *et al.* (2009). miR-34a inhibits migration and invasion by down-regulation of c-Met expression in human hepatocellular carcinoma cells. *Cancer Lett*, 275(1): 44-53.

- Li T, Yin J, Yuan L, Wang S, Yang L, Du X, *et al.* (2014). Downregulation of microRNA-139 is associated with hepatocellular carcinoma risk and short-term survival. *Oncol Rep*, 31(4): 1699-706.
- Li XJ, Ren ZJ, & Tang JH (2014). *MicroRNA-34a*: a potential therapeutic target in human cancer. *Cell Death Dis*; 5: e1327.
- Li Y, Di C, Li W, Cai W, Tan X, Xu L, *et al.* (2016). Oncomirs miRNA-221/222 and Tumor Suppressors miRNA-199a/195 are Crucial miRNAs in Liver Cancer: A Systematic Analysis. *Dig Dis Sci*, 61(8): 2315-27.
- Liebman HA. (1989). Isolation and characterization of a hepatoma associated abnormal (des-gamma-carboxy) prothrombin. *Cancer Res*, 49(23): 6493-7.
- Liu AM, Zhang C, Burchard J, Fan ST, Wong KF, Dai H, *et al.* (2011). Global regulation on microRNA in hepatitis B virus-associated hepatocellular carcinoma. *OMICS*, 15(3):187–91.
- Liu CG, Calin GA, Meloon B, Gamlie N, Sevignani C, Ferracin M, *et al.* (2004). An oligonucleotide microchip for genome-wide microRNA profiling in human and mouse tissues. *Proc Natl Acad Sci USA*; 101(26): 9740–4.
- Liu J, Carmell MA, Rivas FV, Marsden CG, Thomson JM, Song JJ, *et al.* (2004). Argonaute2 is the catalytic engine of mammalian RNAi. *Science*, 305: 1437–41.
- Liu Q, Fu H, Sun F, Zhang H, Tie Y, Zhu J, *et al.* (2008). miR-16 family induces cell cycle arrest by regulating multiple cell cycle genes. *Nucleic Acids Res.*, 36(16): 5391–5404.
- Lodygin D, Tarasov V, Epanchintsev A, Berking C, Knyazeva T, Korner H, *et al.* (2008). Inactivation of miR34a by aberrant CpG methylation in multiple types of cancer. *Cell Cycle*, 7: 2591–2600.
- Lok AS, Sterling RK, Everhart JE, Wright EC, Hoefs JC, Di Bisceglie AM, *et al.* (2010). Des-gamma-carboxy prothrombin and α -fetoprotein as biomarkers for the early detection of hepatocellular carcinoma. *Gastroenterology*, 138(2): 493-502
- Lund E, Guttinger S, Calado A, Dahlberg JE, & Kutay U. (2004). Nuclear export of microRNA precursors. *Science*, 303: 95–98.
- Luo J, Chen M, Huang H, Yuan T, Zhang M, Zhang K, *et al.* (2013). Circulating microRNA-122a as a diagnostic marker for hepatocellular carcinoma. *Onco Targets Ther*, 6: 577-83.
- Manns MP, Buti M, Gane E, Pawlotsky JM, Razavi H, Terrault N, *et al.* (2017). Hepatitis C virus infection. *Nat Rev Dis Primers*, 3(17006): doi: 10.1038/nrdp.2017.6.

- Marquez RT, Bandyopadhyay S, Wendlandt EB, Keck K, Hoffer BA, Icardi MS, *et al.* (2010). Correlation between microRNA expression levels and clinical parameters associated with chronic hepatitis C viral infection in humans. *Lab Invest*, 90(12): 1727-36.
- Marrero JA, Feng Z, Wang Y, Nguyen MH, Befeler AS, Roberts LR, *et al.* (2009). Alpha-fetoprotein, des-gamma carboxyprothrombin, and lectin-bound alpha-fetoprotein in early hepatocellular carcinoma. *Gastroenterology*, 137(1): 110-8
- Marrero JA, Romano PR, Nikolaeva O, Steel L, Mehta A, Fimmel CJ, *et al.* (2015). GP73, a resident Golgi glycoprotein, is a novel serum marker for hepatocellular carcinoma. *J Hepatol*, 43(6): 1007-12.
- Marrero JA, Su GL, Wei W, Emick D, Conjeevaram HS, Fontana RJ, *et al.* (2003). Des-gamma carboxyprothrombin can differentiate hepatocellular carcinoma from nonmalignant chronic liver disease in American patients. *Hepatology*, 37(5): 1114-21
- Matsubara T, Kanto T, Kuroda S, Yoshio S, Higashitani K, Kakita N, *et al.* (2013). TIE2-expressing monocytes as a diagnostic marker for hepatocellular carcinoma correlates with angiogenesis. *Hepatology*, 57(4): 1416-25.
- Matsuzaki J & Suzuki H. (2015). Role of MicroRNAs-221/222 in Digestive Systems. *J Clin Med*, 4(8): 1566-77.
- McCarthy N. (2010). Cancer: Small losses, big gains with microRNAs. *Nat Rev Genet*, 11(1):8.
- Meister G, Landthaler M, Patkaniowska A, Dorsett Y, Teng G, & Tuschl T. (2004). Human Argonaute2 mediates RNA cleavage targeted by miRNAs and siRNAs. *Mol Cell*, 15: 185–97.
- Miao HL, Lei CJ, Qiu ZD, Liu ZK, Li R, Bao ST, *et al.* (2014). MicroRNA-520c-3p inhibits hepatocellular carcinoma cell proliferation and invasion through induction of cell apoptosis by targeting glypican-3. *Hepatol Res*, 44(3): 338-48.
- Ministry of Health and Population, El-Zanaty and Associates, & ICF International (2015). Egypt health issues survey 2015. *DHS Program* <https://dhsprogram.com/pubs/pdf/FR313/FR313.pdf>.
- Mitchell PS, Parkin RK, Kroh EM, Fritz BR, Wyman SK, Pogosova-Agadjanyan EL, *et al.* (2008). Circulating microRNAs as stable blood-based markers for cancer detection. *Proc Natl Acad Sci USA*, 105(30): 10513–8.
- Mohamoud YA, Mumtaz GR, Riome S, Miller D, Abu-Raddad LJ. (2013). The epidemiology of hepatitis C virus in Egypt: a systematic review and data synthesis. *BMC Infect Dis*, 13: 288.
- Morita K, Taketomi A, Shirabe K, Umeda K, Kayashima H, Ninomiya M, *et al.* (2011). Clinical significance and potential of hepatic microRNA-122 expression in hepatitis C. *Liver Int*, 31(4): 474-84.

- Motawi TM, Sadik NA, Shaker OG, & Ghaleb MH (2016). Elevated serum microRNA-122/222 levels are potential diagnostic biomarkers in Egyptian patients with chronic hepatitis C but not hepatic cancer. *Tumor Biol.*, 37(7): 9865-9874.
- Mourad L., El-Ahwany E., Zoheiry M., Abu-Taleb H., Hassan M., Abdel Rehim A., *et al.* (2017). Expression analysis of liver-specific circulating microRNAs in HCV-induced hepatocellular carcinoma in Egyptian Patients. Poster to be presented at the International Liver Cancer Association (ILCA) meeting, Seoul, South Korea.
- Nagai H, Negrini M, Carter SL, Gillum DR, & Rosenberg AL. (1995). Detection and cloning of a common region of loss of heterozygosity at chromosome 1p in breast cancer. *Cancer Res*, 55: 1752–1757.
- Nahon P & Zucman-Rossi J. (2012). Single nucleotide polymorphisms and risk of hepatocellular carcinoma in cirrhosis. *J Hepatol*, 57(3):663–74.
- Nakao K, Miyaaki H, & Ichikawa T. (2014). Antitumor function of microRNA-122 against hepatocellular carcinoma. *J Gastroenterol*, 49(4): 589-93.
- Nault JC, De Reyniès A, Villanueva A, Calderaro J, Rebouissou S, Couchy G, *et al.* (2013). A hepatocellular carcinoma 5-gene score associated with survival of patients following liver resection. *Gastroenterology*, 145(1):176–87.
- Ng EK, Chong WW, Jin H, Lam EK, Shin VY, Yu J, *et al.* (2009). Differential expression of microRNAs in plasma of patients with colorectal cancer: a potential marker for colorectal cancer screening. *Gut*, 58(10): 1375–81.
- Noda I, Kitamoto M, Nakahara H, Hayashi R, Okimoto T, Monzen Y, *et al.* (2010). Regular surveillance by imaging for early detection and better prognosis of hepatocellular carcinoma in patients infected with hepatitis C virus. *J Gastroenterol*, 45: 105-112.
- Penin F, Dubuisson J, Rey FA, Moradpour D & Pawlotsky JM (2004). Structural biology of hepatitis C virus. *Hepatology*, 39(1): 5–19.
- Pineau P, Volinia S, McJunkin K, Marchio A, Battiston C, Terris B, *et al.* (2010). miR-221 overexpression contributes to liver tumorigenesis. *Proc Natl Acad Sci U S A*, 107(1): 264-269.
- Porta C, De Amici M, Quaglini S, Paglino C, Tagliani F, Boncimino A, *et al.* (2008). Circulating interleukin-6 as a tumor marker for hepatocellular carcinoma. *Ann Oncol*, 19(2): 353-8.
- Qi P, Zhou XY, & Du X (2016). Circulating long non-coding RNAs in cancer: current status and future perspectives. *Mol Cancer*, 15(1): 39.
- Qiu G, Lin Y, Zhang H, & Wu D (2015). MiR-139 inhibits epithelial-mesenchymal transition, migration and invasion of hepatocellular carcinoma cells by targeting ZEB1 and ZEB2. *Biochem Biophys Res Commun*, 463(3): 315-21.

- Qu KZ, Zhang K, Li H, Afdhal NH, & Albitar M. (2011). Circulating MicroRNAs as Biomarkers for Hepatocellular Carcinoma. *J Clin Gastroenterol*, 45(4): 355-60.
- Rao MR, Naficy AB, Darwish MA, Darwish NM, Schisterman E, Clemens JD, *et al.* (2002). Further evidence for association of hepatitis C infection with parenteral schistosomiasis treatment in Egypt. *BMC Infect Dis.*, 2: 29.
- Raver-Shapira N, Marciano E, Meiri E, Spector Y, Rosenfeld N, Moskovits N, *et al.* (2007). Transcriptional activation of miR-34a contributes to p53-mediated apoptosis. *Mol Cell*, 26(5): 731-43.
- Resnick KE, Alder H, Hagan JP, Richardson DL, Croce CM, & Cohn DE (2009). The detection of differentially expressed microRNAs from the serum of ovarian cancer patients using a novel real-time PCR platform. *Gynecol Oncol*, 112(1): 55-9.
- Rodríguez-Muñoz Y, Martín-Vílchez S, López-Rodríguez R, Hernández-Bartolomé A, Trapero-Marugán M, Borque MJ, *et al.* (2011). Peripheral blood monocyte subsets predict antiviral response in chronic hepatitis C. *Aliment Pharmacol Ther*, 34(8): 960-71.
- Rokavec M, Li H, Jiang L, & Hermeking H (2014). The p53/miR-34 axis in development and disease. *J Mol Cell Biol*, 6(3): 214-30.
- Sachdeva M, Zhu S, Wu F, Wu H, Walia V, Kumar S, *et al.* (2009). p53 represses c-Myc through induction of the tumor suppressor miR-145. *Proc Natl Acad Sci USA*, 106 (9): 3207-12.
- Sanchez-Beato M, Sanchez-Aguilera A, & Piris MA. (2003). Cell cycle deregulation in B-cell lymphomas. *Blood*, 101: 1220-1235.
- Schmittgen TD & Livak KJ. (2008). Analyzing real-time PCR data by the comparative C_T method. *Nat Protoc*, 3(6): 1101-8.
- Schöler N, Langer C, Döhner H, Buske C, & Kuchenbauer F. (2010). Serum microRNAs as a novel class of biomarkers: a comprehensive review of literature. *Exp Hematol*, 38(12): 1126-30.
- Schuppan D, Ruehl M, Somasundaram R, & Hahn EG. (2001). Matrix as modulator of stellate cell and hepatic fibrogenesis. *Semin Liver Dis*, 21(3): 351-72.
- Scott GK, Goga A, Bhaumik D, Berger CE, Sullivan CS, & Benz CC. (2007). Coordinate Suppression of ERBB2 and ERBB3 by Enforced Expression of Micro-RNA miR-125a or miR-125b. *J Biol Chem*, 282(2): 1479-86.
- Sharma SV & Settleman J. (2007). Oncogene addiction: setting the stage for molecularly targeted cancer therapy. *Genes Dev*, 21(24):3214-31

- Shen J, Wang Q, Gurvich I, Remotti H, & Santella RM (2016). Evaluating normalization approaches for the better identification of aberrant microRNAs associated with Hepatocellular Carcinoma. *Hepatoma Res*, 2: 305-315.
- Shen J, Wang S, Zhang YJ, Kappil M, Wu HC, Kibriya MG, *et al.* (2012). Genome-wide DNA methylation profiles in hepatocellular carcinoma. *Hepatology*, 55(6):1799–808.
- Shen Q, Cicinnati VR, Zhang X, Iacob S, Weber F, Sotiropoulos GC, *et al.* (2010). Role of microRNA-199a-5p and discoidin domain receptor 1 in human hepatocellular carcinoma. *Mol Cancer*, 9: 227.
- Sherman M, Bruix J, Porayko M, & Tran T. (2012). Screening for hepatocellular carcinoma: the rationale for the American Association for the Study of Liver Diseases recommendations. *Hepatology*, 56: 793-796.
- Sherman M. (2011). Current status of alpha-fetoprotein testing. *Gastroenterol Hepatol (N Y)*, 7: 113-4
- Shi M, Du L, Liu D, Qian L, Hu M, Yu M, *et al.* (2012). Glucocorticoid regulation of a novel HPV-E6-p53-miR-145 pathway modulates invasion and therapy resistance of cervical cancer cells. *J Pathol.*, 228: 148–57.
- Siemens H, Jackstadt R, Hunten S, Kaller M, Menssen A, Gotz U, *et al.* (2011). MiR-34 and SNAIL form a double-negative feedback loop to regulate epithelial-mesenchymal transitions. *Cell Cycle*, 10: 4256–4271.
- Simmonds P. (2013). The origin of hepatitis C virus. *Curr. Top. Microbiol. Immunol.* 369, 1–15.
- Singal A, Volk ML, Waljee A, Salgia R, Higgins P, Rogers MA, *et al.* (2009). Meta-analysis: surveillance with ultrasound for early-stage hepatocellular carcinoma in patients with cirrhosis. *Aliment Pharmacol Ther*, 30: 37-47
- Song J, Gao L, Yang G, Tang S, Xie H, Wang Y, *et al.* (2014). MiR-199a Regulates Cell Proliferation and Survival by Targeting FZD7. *PLoS One*, 9(10): e110074.
- Sterling RK, Jeffers L, Gordon F, Sherman M, Venook AP, Reddy KR, *et al.* (2007). Clinical utility of AFP-L3% measurement in North American patients with HCV-related cirrhosis. *Am J Gastroenterol*, 102(10): 2196-205
- Suh SO, Chen Y, Zaman MS, Hirata H, Yamamura S, Shahryari V, *et al.* (2011). MicroRNA-145 is regulated by DNA methylation and p53 gene mutation in prostate cancer. *Carcinogenesis*, 32(5), 772–778.
- Sun YM, Lin KY, & Chen YQ. (2013). Diverse functions of miR-125 family in different cell contexts. *J Hematol Oncol*, 6: 6.

- Tan Y, Ge G, Pan T, Wen D, Chen L, Yu X, *et al.* (2014). A Serum MicroRNA Panel as Potential Biomarkers for Hepatocellular Carcinoma Related with Hepatitis B Virus. *PLoS One*, 9(9): e107986.
- Tangkijvanich P, Chanmee T, Komtong S, Mahachai V, Wisedopas N, Pothacharoen P, *et al.* (2010). Diagnostic role of serum glypican-3 in differentiating hepatocellular carcinoma from non-malignant chronic liver disease and other liver cancers. *J Gastroenterol Hepatol*, 25(1):129-37.
- Tao Y, Ruan J, Yeh SH, Lu X, Wang Y, Zhai W, *et al.* (2011). Rapid growth of a hepatocellular carcinoma and the driving mutations revealed by cell-population genetic analysis of whole-genome data. *Proc Natl Acad Sci U S A*, 108(29):12042-7.
- Taylor DD & Gercel-Taylor C. (2008). MicroRNA signatures of tumor-derived exosomes as diagnostic biomarkers of ovarian cancer. *Gynecol Oncol*, 110(1): 13-21.
- The Polaris Observatory HCV Collaborators (2017). Global prevalence and genotype distribution of hepatitis C virus infection in 2015: a modelling study. *Lancet Gastroenterol. Hepatol.*, 2(3): 161-176.
- Tinkle CL & Haas-Kogan D. (2012). Hepatocellular carcinoma: natural history, current management, and emerging tools. *Biologics*, 6:207-19.
- Trevisani F, De Notariis S, Rapaccini G, Farinati F, Benvegnù L, Zoli M, *et al.* (2002). Semiannual and annual surveillance of cirrhotic patients for hepatocellular carcinoma: effects on cancer stage and patient survival (Italian experience). *Am J Gastroenterol*, 97(3): 734-44.
- Tsai WC, Hsu SD, Hsu CS, Lai TC, Chen SJ, Shen R, *et al.* (2012). MicroRNA-122 plays a critical role in liver homeostasis and hepatocarcinogenesis. *J Clin Invest.*, 122(8): 2884-97.
- Turchinovich A, Weiz L, Langheinz A, & Burwinkel B. (2011). Characterization of extracellular circulating microRNA. *Nucleic Acids Res*, 39(16): 7223-33.
- van Meer S, de Man RA, Siersema PD, & van Erpecum KJ. (2013). Surveillance for Hepatocellular Carcinoma in Chronic Liver Disease: Evidence and Controversies. *World J Gastroenterol*, 19(40): 6744-56.
- Villanueva A, Hoshida Y, Battiston C, Tovar V, Sia D, Alsinet C, *et al.* (2011). Combining clinical, pathology, and gene expression data to predict recurrence of hepatocellular carcinoma. *Gastroenterology*, 140 (5):1501-12 e2.
- Vogelstein, B., Lane, D., & Levine, A.J. (2000). Surfing the p53 network. *Nature*, 408(6810): 307-10.
- Voller A, Bartlett A, & Bidwell DE. (1978). Enzyme immunoassays with special reference to ELISA techniques. *J Clin Pathol*, 31(6): 507-20.

- Waly Raphael S, Yangde Z, & Yuxiang C. (2012). Hepatocellular Carcinoma: Focus on Different Aspects of Management. *ISRN Oncol*, 421673.
- Wang J, Chen J, & Sen S (2016). MicroRNA as Biomarkers and Diagnostics. *J Cell Physiol*, 231(1): 25-30
- Wang Y, Hu C, Cheng J, Chen B, Ke Q, Lv Z, *et al.* (2014). MicroRNA-145 suppresses hepatocellular carcinoma by targeting IRS1 and its downstream Akt signaling. *Biochem Biophys Res Commun*, 446(4): 1255-60.
- Westbrook RH & Dusheiko G. (2014). Natural history of hepatitis C. *J Hepatol.*, 61(1): S58–S68.
- Wild T, Horvath P, Wyler E, Widmann B, Badertscher L, Zemp I, *et al.* (2010). A protein inventory of human ribosome biogenesis reveals an essential function of exportin 5 in 60S subunit export. *PLoS Biol*, 8(10):e1000522.
- Wong CC, Wong CM, Tung EK, Au SL, Lee JM, Poon RT, *et al.* (2011). The MicroRNA miR-139 Suppresses Metastasis and Progression of Hepatocellular Carcinoma by Down-regulating Rho-Kinase 2. *Gastroenterology*, 140(1): 322-31.
- Xu H, He J-H, Xiao Z-D, Zhang Q-Q, Chen Y-Q, Zhou H, *et al.* (2010). Liver-enriched transcription factors regulate microRNA-122 that targets CUTL1 during liver development. *Hepatology*, 52:1431–1442.
- Yang XW, Zhang LJ, Huang XH, Chen LZ, Su Q, Zeng WT, *et al.* (2014). miR-145 suppresses cell invasion in hepatocellular carcinoma cells: miR-145 targets ADAM17. *Hepatol Res*, 44(5): 551-559.
- Yap TA, Gerlinger M, Futreal PA, Pusztai L, & Swanton C. (2012). Intratumor heterogeneity: seeing the wood for the trees. *Sci Transl Med*, 4(127):127ps10.
- Yasuda E, Kumada T, Toyoda H, Kaneoka Y, Maeda A, Okuda S, *et al.* (2010). Evaluation for clinical utility of GPC3, measured by a commercially available ELISA kit with Glypican-3 (GPC3) antibody, as a serological and histological marker for hepatocellular carcinoma. *Hepatol Res*, 40(5): 477-85.
- Yi R, Qin Y, Macara IG, & Cullen BR. (2003). Exportin-5 mediates the nuclear export of pre-microRNAs and short hairpin RNAs. *Genes Dev*, 17: 3011–3016.
- Yu L, Ding GF, He C, Sun L, Jiang Y, & Zhu L (2014). MicroRNA-424 is down-regulated in hepatocellular carcinoma and suppresses cell migration and invasion through c-Myb. *PLoS One*, 9(3): e91661.

Zhang H, Zhai Y, Hu Z, Wu C, Qian J, Jia W, *et al.* (2010). Genome-wide association study identifies 1p36.22 as a new susceptibility locus for hepatocellular carcinoma in chronic hepatitis B virus carriers. *Nat Genet*, 42: 755–758.

Zheng J, Zhou Z, Xu Z, Li G, Dong P, Chen Z, *et al.* (2015). Serum microRNA-125a5p, a useful biomarker in liver disease, correlates with disease progression. *Mol Med Rep*, 12(1): 1584-90.

Zinkin NT, Grall F, Bhaskar K, Otu HH, Spentzos D, Kalmowitz B, *et al.* (2008). Serum proteomics and biomarkers in hepatocellular carcinoma and chronic liver disease. *Clin Cancer Res*, 14(2): 470–77.

XII. APPENDIX

A. Copyright Clearances & Permissions



RightsLink®



Title: Hepatitis C virus infection
Author: Michael P. Manns, Maria Buti, Ed Gane, Jean-Michel Pawlotsky, Homie Razavi et al.
Publication: Nature Reviews Disease Primers
Publisher: Nature Publishing Group
Date: Mar 2, 2017
Copyright © 2017, Rights Managed by Nature Publishing Group

Logged in as:

Lobna Mourad

Account #:

3001137775

LOGOUT

Order Completed

Thank you for your order.

This Agreement between Lobna Mourad ("You") and Nature Publishing Group ("Nature Publishing Group") consists of your license details and the terms and conditions provided by Nature Publishing Group and Copyright Clearance Center.

Your confirmation email will contain your order number for future reference.

[Printable details.](#)

| | |
|------------------------------|---|
| License Number | 4147051418473 |
| License date | Jul 13, 2017 |
| Licensed Content Publisher | Nature Publishing Group |
| Licensed Content Publication | Nature Reviews Disease Primers |
| Licensed Content Title | Hepatitis C virus infection |
| Licensed Content Author | Michael P. Manns, Maria Buti, Ed Gane, Jean-Michel Pawlotsky, Homie Razavi et al. |

| | |
|--|--|
| Licensed Content Date | Mar 2, 2017 |
| Licensed Content Volume | 3 |
| Type of Use | reuse in a dissertation / thesis |
| Requestor type | academic/educational |
| Format | print and electronic |
| Portion | figures/tables/illustrations |
| Number of figures/tables/illustrations | 2 |
| High-res required | no |
| Figures | Figures 2 and 3 |
| Author of this NPG article | no |
| Your reference number | |
| Title of your thesis / dissertation | Expression Analysis of Liver-Specific Circulating MicroRNAs in HCV-Induced Hepatocellular Carcinoma in Egyptian Patients |
| Expected completion date | Jun 2017 |
| Estimated size (number of pages) | 100 |
| | Lobna Mourad 19 Kornish El Nile, Maadi |
| Requestor Location | Cairo, other Egypt Attn: |
| Billing Type | Invoice Lobna Mourad 19 Kornish El Nile, Maadi |
| Billing address | Cairo, Egypt Attn: Lobna Mourad |
| Total | 0.00 USD |

[1. *Hepatic Medicine : Evidence and Research*](#)

- **ISSN:** 1179-1535
- **Publication Type:** e-Journal
- **Volume:**

- **Issue:**
- **Start page:**
- **Publisher:** Dove Medical Press
- **Permission type:** Republish or display content
- **Type of use:** Republish in a thesis/dissertation

| | |
|---|---|
| Requestor type | Author of requested content |
| Format | Print, Electronic |
| Portion | chart/graph/table/figure |
| Number of charts/graphs/tables/figures | 1 |
| Title or numeric reference of the portion(s) | Figure 1 B |
| Title of the article or chapter the portion is from | Hepatitis C infection in Egypt: prevalence, impact and management strategies. |
| Editor of portion(s) | N/A |
| Author of portion(s) | Gomaa A, Allam N, Elsharkway A, El Kassas M, Waked I |
| Volume of serial or monograph | N/A |
| Page range of portion | 100 |
| Publication date of portion | October 2017 |
| Rights for | Main product |
| Duration of use | Life of current edition |
| Creation of copies for the disabled | no |
| With minor editing privileges | no |
| For distribution to | Worldwide |
| In the following language(s) | Original language of publication |
| With incidental promotional use | yes |
| Lifetime unit quantity of new product | Up to 499 |
| Made available in the following markets | Education |
| The requesting person/organization | Lobna Mourad |
| Order reference number | |
| Author/Editor | Lobna Mourad |
| The standard identifier of New Work | The American University in Cairo |

| | |
|---------------------------|--|
| Title of New Work | Expression Analysis of Liver-Specific Circulating MicroRNAs in HCV-Induced Hepatocellular Carcinoma in Egyptian Patients |
| Publisher of New Work | The American University in Cairo |
| Expected publication date | Oct 2017 |
| Estimated size (pages) | 100 |

Dove Medical Press Ltd. LICENSE
TERMS AND CONDITIONS
May 30, 2017

This is a License Agreement between Lobna Mourad ("You") and Dove Medical Press Ltd. ("Dove Medical Press Ltd.") provided by Copyright Clearance Center ("CCC"). The license consists of your order details, the terms and conditions provided by Dove Medical Press Ltd., and the payment terms and conditions.

All payments must be made in full to CCC. For payment instructions, please see information listed at the bottom of this form.

| | |
|---|---|
| License Number | 4085880165792 |
| License date | Apr 11, 2017 |
| Licensed content publisher | Dove Medical Press Ltd. |
| Licensed content title | Hepatic Medicine : Evidence and Research |
| Licensed content date | Jan 1, 2009 |
| Type of Use | Thesis/Dissertation |
| Requestor type | Author of requested content |
| Format | Electronic |
| Portion | image/photo |
| Number of images/photos requested | 4 |
| Title or numeric reference of the portion(s) | Figure 1, Figure 2, Figure 4, Figure 5, Table 1, Table 2 |
| Title of the article or chapter the portion is from | N/A |
| Editor of portion(s) | N/A |
| Author of portion(s) | N/A |
| Volume of serial or monograph. | N/A |
| Page range of the portion | 20-26 |

| | |
|---|--|
| Publication date of portion | 2012 |
| Rights for | Main product |
| Duration of use | Current edition and up to 5 years |
| Creation of copies for the disabled | no |
| With minor editing privileges | no |
| For distribution to | United States |
| In the following language(s) | Original language of publication |
| With incidental promotional use | no |
| The lifetime unit quantity of new product | Up to 499 |
| Made available in the following markets | Education |
| The requesting person/organization is: | Lobna Mourad |
| Order reference number | |
| Author/Editor | Lobna Mourad |
| The standard identifier of New Work | The American University in Cairo |
| Title of New Work | Expression Analysis of Liver-Specific Circulating MicroRNAs in HCV-Induced Hepatocellular Carcinoma in Egyptian Patients |
| Publisher of New Work | The American University in Cairo |
| Expected publication date | Jun 2017 |
| Estimated size (pages) | 100 |

NATURE PUBLISHING GROUP LICENSE
TERMS AND CONDITIONS
May 30, 2017

This Agreement between Lobna Mourad ("You") and Nature Publishing Group ("Nature Publishing Group") consists of your license details and the terms and conditions provided by Nature Publishing Group and Copyright Clearance Center.

| | |
|------------------------------|---|
| License Number | 4085900498178 |
| License date | Apr 11, 2017 |
| Licensed Content Publisher | Nature Publishing Group |
| Licensed Content Publication | Cell Death and Differentiation |
| Licensed Content Title | The miR-34 family in cancer and apoptosis |
| Licensed Content Author | H Hermeking |
| Licensed Content Date | May 22, 2009 |
| Licensed Content Volume | 17 |

| | |
|--|--|
| Licensed Content Issue | 2 |
| Type of Use | reuse in a dissertation / thesis |
| Requestor type | academic/educational |
| Format | electronic |
| Portion | figures/tables/illustrations |
| Number of figures/tables/illustrations | 2 |
| High-res required | no |
| Figures | Figure 1 and Figure 2 |
| Author of this NPG article | no |
| Your reference number | |
| Title of your thesis / dissertation | Expression Analysis of Liver-Specific Circulating MicroRNAs in HCV-Induced Hepatocellular Carcinoma in Egyptian Patients |
| Expected completion date | Jun 2017 |
| Estimated size (number of pages) | 100 |
| | Lobna Mourad 19 Kornish El Nile, Maadi |
| Requestor Location | Cairo, other Egypt Attn: |
| Billing Type | Invoice Lobna Mourad 19 Kornish El Nile, Maadi |
| Billing Address | Cairo, Egypt Attn: Lobna Mourad |

OXFORD UNIVERSITY PRESS LICENSE
TERMS AND CONDITIONS
May 30, 2017

This Agreement between Lobna Mourad ("You") and Oxford University Press ("Oxford University Press") consists of your license details and the terms and conditions provided by Oxford University Press and Copyright Clearance Center.

License Number 4086530034452

| | |
|------------------------------|--|
| License date | Apr 12, 2017 |
| Licensed content publisher | Oxford University Press |
| Licensed content publication | Journal of Molecular Cell Biology |
| Licensed content title | The p53/miR-34 axis in development and disease |
| Licensed content author | Rokavec, Matjaz; Li, Huihui |
| Licensed content date | Jun 1, 2014 |
| Type of Use | Thesis/Dissertation |
| Institution name | |
| Title of your work | Expression Analysis of Liver-Specific Circulating MicroRNAs in HCV-Induced Hepatocellular Carcinoma in Egyptian Patients |
| Publisher of your work | n/a |
| Expected publication date | Jun 2017 |
| Permissions cost | 0.00 USD |
| Value added tax | 0.00 USD |
| Total | 0.00 USD |
| | Lobna Mourad 19 Kornish El Nile, Maadi |
| Requestor Location | Cairo, other Egypt Attn: |
| Publisher Tax ID | GB125506730 |
| Billing Type | Invoice Lobna Mourad 19 Kornish El Nile, Maadi |
| Billing Address | Cairo, Egypt Attn: Lobna Mourad |

ELSEVIER LICENSE
TERMS AND CONDITIONS
May 31, 2017

This Agreement between Lobna Mourad ("You") and Elsevier ("Elsevier") consists of your license details and the terms and conditions provided by Elsevier and Copyright Clearance Center.

| | |
|--|--|
| License Number | 4085930599620 |
| License date | Apr 11, 2017 |
| Licensed Content Publisher | Elsevier |
| Licensed Content Publication | Biochemical and Biophysical Research Communications |
| Licensed Content Title | Expression of serum miR-221 in human hepatocellular carcinoma and its prognostic significance |
| Licensed Content Author | Jipeng Li, Yiping Wang, Wanjun Yu, Jun Chen, Jianping Luo |
| Licensed Content Date | Mar 4, 2011 |
| Licensed Content Volume | 406 |
| Licensed Content Issue | 1 |
| Licensed Content Pages | 4 |
| Start Page | 70 |
| End Page | 73 |
| Type of Use | reuse in a thesis/dissertation |
| Intended publisher of new work | other |
| Portion | figures/tables/illustrations |
| Number of figures/tables/illustrations | 2 |
| Format | electronic |
| Are you the author of this Elsevier article? | No |
| Will you be translating? | No |
| Order reference number | |
| Original figure numbers | Figure 1 and Figure 2 |
| Title of your thesis/dissertation | Expression Analysis of Liver-Specific Circulating MicroRNAs in HCV-Induced Hepatocellular Carcinoma in Egyptian Patients |
| Expected completion date | Jun 2017 |
| Estimated size (number of pages) | 100 |

Elsevier VAT number

GB 494 6272 12

Lobna Mourad
19 Kornish El Nile, Maadi

Requestor Location

Cairo, other
Egypt
Attn:



RightsLink®

Home

Account Info

Help



Title: MicroRNA-34a: a potential therapeutic target in human cancer
Author: X J Li, Z J Ren and J H Tang
Publication: Cell Death & Disease
Publisher: Nature Publishing Group
Date: Jul 1, 2014
Copyright © 2014, Rights Managed by Nature Publishing Group

Logged in as:
Lobna Mourad
Account #:
3001137775

LOGOUT

Creative Commons

The request you have made is considered to be non-commercial/educational. As the article you have requested has been distributed under a Creative Commons license (Attribution-Noncommercial), you may reuse this material for non-commercial/educational purposes without obtaining additional permission from Nature Publishing Group, providing that the author and the original source of publication are fully acknowledged (please see the article itself for the license version number). You may reuse this material without obtaining permission from Nature Publishing Group, providing that the author and the original source of publication are fully acknowledged, as per the terms of the license. For license terms, please see <http://creativecommons.org/>



RightsLink®

Home

Account Info

Help





Title: miR-122 – A key factor and therapeutic target in liver disease
Author: Simonetta Bandiera, Sébastien Pfeffer, Thomas F. Baumert, Mirjam B. Zeisel
Publication: Journal of Hepatology
Publisher: Elsevier
Date: February 2015
© 2014 European Association for the Study of the Liver. Published by Elsevier B.V.

Logged in as:

Lobna Mourad

Account #:

3001137775

LOGOUT

Creative Commons Attribution-NonCommercial-No Derivatives License (CC BY NC ND)

This article is published under the terms of the [Creative Commons Attribution-NonCommercial-No Derivatives License \(CC BY NC ND\)](#).

For non-commercial purposes you may copy and distribute the article, use portions or extracts from the article in other works, and text or data mine the article, provided you do not alter or modify the article without permission from Elsevier. You may also create adaptations of the article for your own personal use only, but not distribute these to others. You must give appropriate credit to the original work, together with a link to the formal publication through the relevant DOI, and a link to the Creative Commons user license above. If changes are permitted, you must indicate if any changes are made but not in any way that suggests the licensor endorses you or your use of the work.

Permission is not required for this non-commercial use. For commercial use please continue to request permission via Rightslink.

B. Generic Consent Form – Adult

مقترح الموافقة المستنيرة

عنوان البحث (الدراسة):

ملخص موجز: يعتبر فيروس التهاب الكبدى الوبائى سى من الأسباب الرئيسية المسببة لأمراض الكبد المزمنة. وقد كشفت الدراسات الحديثة مساهمة الأحماض النووية الدقيقة فى الاليات المرضية للعديد من الأمراض التى تصيب الانسان بما فى ذلك أمراض الكبد. وبناءا على تلك المعلومات يمكن استخدام هذه التغييرات الجينية والأحماض النووية فى الدم كمؤشرات حيوية للكشف عن الأمراض.

الباحث الرئيسى: أ.د/ منى كامل زهيرى

الباحثون المشاركون: , أ.د/ ايمان الأهوانى, د/ لبنى مراد, أ.د/ فاتن مصطفى ناجى, د/ هدى أبوطالب, أ.د/ محمد عباس شمس, د/ مروة حسن

أنت تعاني من مرض التليف الكبدى الوبائى الناتج عن فيروس سى و نحن نقوم بدراسة الأحماض النووية الدقيقة ومقارنتها بمجموعة من الأصحاء وسوف نستعين بعدد 165 مريض لإمكان التوصل الى معرفة عدد معين من الأحماض النووية الدقيقة السابحة فى الدم حيث يمكن استخدامها كمؤشر لتشخيص وتطور المرض قبل البدء فى افراز النسيج الضام فى الكبد وذلك فى حالات التهاب الكبدى الوبائى سى المنتشر فى مصر.

المطلوب من المشارك فى هذه الدراسة:

لو وافقت على الاشتراك معنا فى هذه الدراسة ، سوف نقوم بأخذ التاريخ المرضى وأخذ عينة دم 5 ملليلتر.
الفائدة: استخدام التغييرات الجينية والأحماض النووية فى الدم كمؤشرات حيوية للكشف عن المرض قبل تطوره.

الاعراض الجانبية: لا توجد

امكانية قبول أو رفض المشاركة:

أنت غير مجبر اطلاقا على المشاركة و كذلك من حقك الانسحاب من الدراسة وقتما تشاء بعد ابلاغ الطبيب المسئول بدون أن يؤثر قرارك على الرعاية الطبية التى تحصل عليها.

من سيعلم بمشاركتك فى البحث :

الأطباء المسئولون عن البحث و كذلك الممرضات المعاونون لهم و لك مطلق الحرية فى ابلاغ من تريد من أهلك و أصدقائك كما أن المعلومات الخاصة بحالتك المرضية وعلاجك ستكون محفوظة بطريقة آمنة غير مسموح بالإطلاع عليها إلا للمسئولين عن البحث.

هل لديك أى استفسارات أخرى ؟

فى حالة رغبتك فى طرح أى سؤال أثناء الدراسة يمكنك توجيهه إلى الدكتور الباحث الرئيسى تليفون : 01115387880

فى حالة رغبتك فى طرح أى شكوى أثناء الدراسة يمكنك توجيهها إلى الاستاذ الدكتور رئيس لجنة أخلاقيات البحث العلمى
بمعهد تيودور بلهارس للأبحاث تليفون: 01008009411.

أقر أنا الموقع أدناه،أننى قد قرأت و فهمت ووافقـت على المشاركة فى الدراسة

الرقم القومى :

التاريخ :

توقيع المشارك :

تليفون المشارك :

عنوان المشارك :

التاريخ :

توقيع الشاهد :

التاريخ :

توقيع الباحث :

C. Institutional Review Board (IRB)

i. The American University in Cairo

2011-2012, case #190



THE AMERICAN UNIVERSITY IN CAIRO
OFFICE OF THE ASSOCIATE PROVOST FOR RESEARCH ADMINISTRATION

To: Lobna Aboul Dahab (Biotechnology student)
Advisor: Suher Zada (Biology)
From: Graham Harman, Chair of the IRB
Date: August 8, 2012
Re: approval of study

This is to inform you that I reviewed your research proposal entitled "MicroRNA as a Novel Diagnostic Tool for HCV-Induced Hepatocellular Carcinoma in Egyptian Students," and determined that it used appropriate procedures to minimize risks to human subjects and that adequate provision was made for confidentiality and data anonymity of participants in any published record. I believe you will also make adequate provision for obtaining informed consent of the subjects. Thus, the proposal qualifies for exempt review, meaning that I have approved it without convening the full Institutional Review Board.

Please note that IRB approval is valid only for one year from the date of this letter. For projects taking longer than one year to complete, IRB approval must be sought again *before* the expiration date of the current approval.

Thank you and good luck.

Graham Harman

ii. Theodor Bilharz Research Institute



معهد تيودور بلهارس للأبحاث
لجنة أخلاقيات البحث العلمي



السيدة الاستاذة الدكتورة / منى زهيرى أستاذ المناعة بالمعهد.

تحية طبية و بعد

تحيط سيادتكم علما بأن لجنة أخلاقيات البحث العلمي قد وافقت على إجراء المشروع وهو بعنوان:

Circulating markers related to influx of the liver with extrahepatic myofibroblast progenitor cells as predictors of HCV- induced hepatic fibrosis and carcinogenesis..

وذلك فى اجتماعها يوم الإثنين ٢٠١٠/٦/١٤ علما بأنه يتعين على سيادتكم إضافة التعديل التالى

فى الموافقة المستنيرة و هو :-

- تحديد عدد المرضى .

- تحديد عينة الدم سم .

وكذلك موافاة اللجنة بالموافقات المستنيرة بعدد المرضى المشتركين فى المشروع عند تقديم التقارير الدورية وكذلك عقب الانتهاء من إجرائه كما يرجى الالتزام بصيغة الموافقة المستنيرة المقدمة من قبل سيادتكم والمعتمدة من قبل اللجنة وستحصلون على الموافقة النهائية ورقم هذه الموافقة وذلك عند تقديم التقرير النهائى.

وتفضلوا سيادتكم بقبول فائق الاحترام...

رئيس لجنة أخلاقيات البحث العلمي

(أ.د سناء ثابت بطرس)

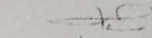
٢٠١٠ / ٧ / ١٦

THEODOR BILHARZ RESEARCH INSTITUTE
Institutional Review Board
www.tbri.gov.eg